

# The Temporal Correlation Hypothesis of Visual Feature Integration: Still Alive and Well

## Review

Charles M. Gray\*

The Center for Neuroscience and  
Section of Neurobiology, Physiology, and Behavior  
University of California, Davis  
Davis, California 95616

In recent years, the binding problem has gained widespread attention among theorists and experimentalists alike. This surge of interest has been driven by the realization that there are few, if any, places in the nervous system where all the information necessary to carry out a particular task is localized. The inescapable conclusion is that sensory, cognitive, and motor processes result from parallel interactions among large populations of neurons distributed among multiple cortical and sub-cortical structures. Binding, in a general sense, is the process responsible for functionally linking this distributed activity. In the visual system, this problem corresponds to identifying the relationships among features in an image so that objects can be recognized. Much of this process relies on focused attention. It has also been recognized, however, that an early preattentive mechanism operates rapidly, and in parallel, to segment visual scenes into their candidate objects. This mechanism, often referred to as perceptual grouping, enables features to be grouped together according to Gestalt, and other, criteria. These processes are also faced with a binding problem. Some form of representation must be available to establish relationships among features and separate one set of grouped features from another. Milner (1974) and von der Malsburg (1981, 1985) proposed that these problems could be overcome if constellations of grouped features were represented dynamically by the formation of cell assemblies, defined by the selective synchronization of distributed neuronal activities. Such a mechanism, they argued, would permit the segregation of one representation from another and provide highly salient neuronal signals to an object-based attentional selection mechanism.

In the ensuing years, evidence has accumulated to support this hypothesis, but critics have argued that it is insufficient to warrant the theory's acceptance. They have also argued that the theory is flawed on physiological grounds, that cortical networks do not possess the requisite mechanisms to generate and make use of selective patterns of neuronal synchronization. In this review, I will argue to the contrary that the theory, particularly as it applies to preattentive vision, is well grounded in the psychophysical and neurophysiological domains. I will focus on the problem of visual perceptual grouping and define the process within the context of a set of principles articulated by Gestalt psychology. I will lay out the framework of the theory for how perceptual grouping is implemented in the visual system. And I will present arguments, couched in neurophysiological

terms, for why I believe this theory is attractive and has gained widespread attention. I will follow with a brief review of the evidence, both for and against, the theory and discuss some of the objections commonly put forth by its critics, in an effort to account for why the theory has been so attractive and so controversial at the same time. I will end with a discussion of specific experiments that are needed to rigorously test the theory and briefly summarize where it stands at present.

### Binding Is a Diverse Set of Functions

Binding isn't a problem for nervous systems, as evolution has sculpted their organization to solve the problem efficiently and effectively. It is only a problem for those of us trying to understand how the nervous system achieves the task. Part of our difficulty stems from the fact that binding is a broadly defined term. It is a function that occurs over multiple spatial and temporal scales of organization in the nervous system. It can be rapid and preattentive or may require focused attention. It can occur within a single sensory modality or may require cross-modal or sensory-motor integration. Consequently, confusion and disagreement can easily arise among competing theories of the binding process and experimental tests of those theories.

To illustrate the richness of the binding process, consider a simple everyday example of a sensory-motor task. You want to find a certain object that's located on one of several adjacent shelves, but you're not sure which shelf, and there are many other objects on the shelves besides the one you're searching for. To find it, you have to visually scan the scene until you recognize the object. At each location of gaze, your visual system must parse the scene into its component objects. This involves identifying which features in the scene belong to which objects. Once this is accomplished, or perhaps at the same time, the identity of a particular object can be evaluated. If it doesn't match what you're searching for, you must direct your gaze to a new location and repeat the process. This redirection of gaze may itself be guided by the prior parsing of the scene. Once you've identified the correct object, you can reach out, grasp it, and carry on with the task at hand.

It is not entirely clear which components of this task we should refer to as binding and hence which neuronal mechanisms solve the "binding problem." Perhaps the most common view is that binding is the process of combining stimulus features to form an object representation. This is intuitively appealing, because it is well established that the locations and properties of local stimulus features are represented within multiple retinotopic cortical maps. The features comprising objects must somehow be "bound" together by combining the appropriate activities within the relevant cortical maps. However, a number of other processes in the task described above can be thought of equally well as binding. Associating the location of an object in space with its identity is one example. Abundant evidence indicates that separate cortical areas participate in the recognition

\*E-mail: cmgray@ucdavis.edu.

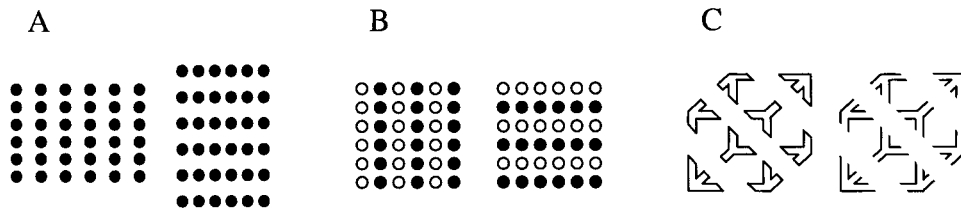

Figure 1. Simple Patterns Illustrating Several Gestalt Principles of Perceptual Grouping

(A) Proximity. The arrays of dots are automatically grouped into columns or rows depending on the nearest neighbor relationships.  
 (B) Similarity. Arrays of equally spaced dots are automatically grouped to form columns or rows depending on the axis of similarity of the features.  
 (C) Closure and collinearity. The diagram on the left appears as a collection of unrelated objects. If a subset of the lines are removed, the collinear alignment of the remaining lines reveals a 3-dimensional Necker cube and several overlapping illusory contours. Adapted from Kanizsa (1979).

and spatial localization of objects. Hence, the need arises to bind the neuronal activities representing “where” an object is with those representing “what” it is. Another compelling example is the association between the sensory representation of objects and the decisions and motor commands to act in relation to those objects. These are functions that clearly involve a coordinated interaction between distributed regions of the brain involved in sensory, cognitive, and motor processing. Thus, it seems reasonable to think of many neuronal functions involving the integration of distributed information as binding processes.

Such a general definition, however, might lead to confusion between processes mediated by different neuronal systems. For example, some binding processes, such as the grouping and segmentation of features, take place preattentively, while others, such as object recognition and aspects of sensory-motor integration, require focused attention. To lump these processes together under the term “binding,” and to then set out to solve the “binding problem,” would appear misguided. Because these processes are so diverse, it is likely that they are mediated by a variety of mechanisms. As a result, we may introduce difficulties (and controversies) in understanding binding mechanisms if we do not constrain the problem.

### Perceptual Grouping Is a Form of Binding

Every time we inspect a visual scene, we are confronted with a complex pattern of features, some static and some moving in various directions and at various velocities. In spite of this complexity, our visual system is able to rapidly identify the features that belong together as objects. In the first half of this century, the field of Gestalt psychology formulated a set of principles specifying the properties of visual features that observers tend to group together (Wertheimer, 1923, 1955; Köhler, 1930; Koffka, 1935, 1969; Kanizsa, 1976). These were features of high visual salience that included their so-called laws or “factors” of proximity, similarity, continuity, closure, and common fate. They discovered that features with these common characteristics tend to be automatically “bound” together as coherent units (Figure 1) and thus often define objects in the real world. This made intuitive sense, given that visual objects tend to be composed of features that are spatially adjacent, have similar appearance, are continuous with one another, form closed

contours, and move coherently together. It should be noted that the characteristics listed above are not the only stimulus features that contribute to grouping. Numerous studies have demonstrated that a variety of other stimulus features, such as size (Bergen and Adelson, 1988), texture (Julesz, 1975), binocular disparity (Nakayama and Silverman, 1986), and coincidence in time (Alais et al., 1998) also contribute to grouping.

The Gestalt psychologists postulated that sensory grouping is an automatic and dynamic process that binds sensory units (features) together into emergent wholes or objects. Grouping was considered to be an early step in perception that preceded recognition. Support for these arguments gained ground when it was discovered that under certain conditions the time required to identify a target in a display did not depend on the number of items in the display (Neisser et al., 1963). Results of this type led to the notion that early visual processing does not depend on a serial process mediated by directed attention. This “preattentive processing” was postulated to occur in parallel over the whole visual field and to provide an initial segmentation of a visual scene into its component objects on the basis of Gestalt properties (Neisser, 1967). Once completed, the signals resulting from the grouping process could then serve as inputs for further analysis using selective attention. Such a mechanism would dramatically reduce the number of elements the attentional system would be required to scrutinize and thereby increase the speed and efficiency of visual search.

In the years since, numerous studies have provided support for the general framework of this hypothesis (Rock and Brosdale, 1964; Beck, 1966, 1967; Kahneman, 1973; Julesz, 1975; Kahneman and Henik, 1981; Pomerantz, 1981; Prinzmetal, 1981; Treisman et al., 1982; Bergen and Julesz, 1983; Duncan, 1984; Bergen and Adelson, 1988; Bravo and Blake, 1990; Elder and Zucker, 1993). In what have come to be known as object-based models, attention is thought to be directed to collections of features that are formed preattentively into primitive objects (Neisser, 1967; Duncan, 1984; Donnelly et al., 1991; Vecera and Farah, 1994; Rensink and Enns, 1995; Wolfe and Bennett, 1996). This suggests that perceptual grouping is an early form of feature binding that identifies and represents relationships among features, and that these representations can be accessed by attentional selection mechanisms. This notion leads to a number of obvious questions. What are the features that are

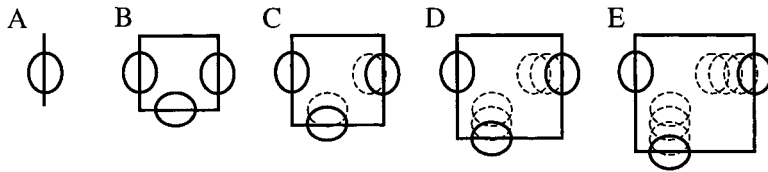

Figure 2. Schematic Diagram Illustrating the Requirement for Flexibility in the Grouping of Visual Features

(A) A vertically oriented contour centered over the receptive field of a hypothetical group of visual cortical neurons.

(B) Grouping of this contour with other local contours to form a square requires the inte-

gration of signals from other cortical neurons that are activated by the other parts of the figure. Two of the hypothetical receptive fields are included.

(C–E) The remaining plots illustrate that there exist a large number of other possible squares that contain a vertical contour overlying the receptive field shown in (A). In each of these examples, the cells activated by this contour must now integrate their activity with those activated by different sets of contours whose receptive fields lie in distinct positions. The dashed ellipses in (C) through (E) illustrate the cumulative positions of the receptive fields for each of the objects.

preferentially grouped together? What type of representation is formed among the grouped features? What are the neurophysiological constraints within which these processes must operate? And what aspects of the representation are prerequisites for attentional selection?

I will argue, as have many others, that these primitive, preattentive objects result from the grouping of features according to Gestalt principles. For simplicity, I will limit my arguments to those feature elements that contribute to form and shape perception. I will further argue that the representation of grouped features must rely in some way on the formation of neuronal assemblies (Hebb, 1949; Braitenberg, 1978; Edelman, 1978; Palm, 1981, 1990; von der Malsburg, 1986; Gerstein et al., 1989). These dynamic structures provide the most parsimonious mechanism to account for the rapid, parallel, and combinatorial nature of perceptual grouping. They also provide a neurophysiologically plausible mechanism for greatly increasing the salience of neuronal activity for subsequent processing stages involving selective attention (Reynolds and Desimone, 1999 [this issue of *Neuron*]). To fully explore these arguments, it is necessary to first describe the properties of perceptual grouping so that the neurophysiological constraints on the task are fully appreciated.

### Properties of Perceptual Grouping

Although perceptual grouping appears to occur effortlessly, several aspects of the process illustrate why it is so difficult to understand mechanistically, and why “binding” has become such a “problem.” First and foremost, perceptual grouping is a flexible process. A given feature element, at a given location in the visual field, may be grouped with one set of elements in one scene and with another, completely different, set of elements in another scene. To illustrate this point, consider the simple diagrams shown in Figure 2. A single vertically oriented contour, located at a fixed position in space (Figure 2A), can be combined with other contours to yield the shape of a square (Figure 2B). If the size of the square changes (Figures 2C–2E), while the position of its upper left vertical contour does not change, then the same vertical contour must be combined with a different set of contours for each configuration of the square. This implies that the neuronal activities signaling the presence and properties of the vertical contour must be combined with different populations of active neurons as the properties of the image change. Taking this simple argument for flexibility one step further, it is easy to

appreciate that the combinatorial capacity of perceptual grouping must be very high. If the vertical contour in Figure 2A is combined with contours of different orientations and positions, a wide variety of shapes are possible (Figure 3). As the relationships among the features change, the grouping process must adapt to cope with the large number of possible combinations. Thus, the activity signaling the vertical contour must be recombined in a flexible manner so that a large number of other feature relationships can be perceptually grouped. Given that visual scenes exist in near infinite variety and constantly appear in novel configurations, the perceptual grouping process appears, for all practical purposes, to have an infinite capacity.

Another readily apparent feature of perceptual grouping is its parallel organization. Features comprising figures, such as those shown in Figures 2 and 3, rarely exist in isolation. Rather, visual scenes are usually composed of complex collections of objects that often overlap or occlude one another. This implies that the grouping of features must take place simultaneously at multiple, and sometimes overlapping, locations of the visual field. When this requirement is combined with the need for flexibility and combinatorial capacity, it is easy to appreciate the inherent complexity of the neuronal processes that must be involved. Multiple sets of features must be grouped simultaneously and perceptually segmented from one another. However, as the visual scene changes, features that are grouped together in one image may be segregated from one another in a different image. This may occur even if the properties of the local features themselves do not change. This notion is illustrated in Figure 4. The plots in Figure 4A show the receptive fields of six hypothetical cortical neurons, each tuned to vertical orientation. One can imagine many constellations of features in which all six of the cells are activated by their preferred local features. The plots in Figures 4B–4D illustrate three such examples. What distinguishes these simple scenes from one another are the obvious differences in perceptual grouping that contribute to the recognition of either two or three distinct figures. In each image, a different pattern of grouping must take place while the local features present in the receptive fields of the cells remain roughly constant. For example, two vertical contours are grouped when they form opposite sides of a square but are segregated from one another when they form components of two different squares. These examples illustrate how perceptual grouping must be both flexible and parallel in

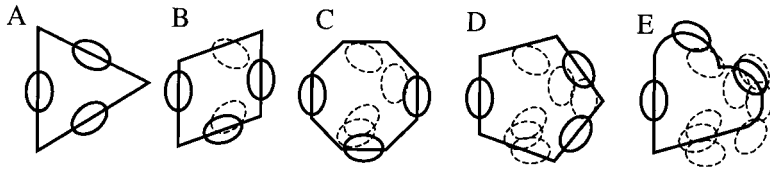

Figure 3. Another Example Illustrating the Combinatorial Complexity of the Grouping Process

The activity of the cells signaling the vertical contour on the left of each figure must be combined with the activity of cells signaling a large number of other possible features. For any given object, a distinct grouping operation

should take place. This indicates that the visual system must be capable of identifying the relationships among a large number of possible feature combinations. For each of the figures, a set of three hypothetical receptive fields are shown. The dashed ellipses in (B) through (E) illustrate the cumulative positions of the receptive fields for each of the objects.

its organization, but they also suggest that competition may occur among grouping criteria such that certain feature relations, like continuity and closure, may tend to dominate over others (Donnelly et al., 1991; Elder and Zucker, 1993; Kovacs and Julesz, 1993).

Finally, another aspect of perceptual grouping, its speed, reveals the truly impressive nature of the process. It is not certain how long a given grouping operation takes to complete, and the duration no doubt varies with the properties of a scene, but estimates usually fall in the range of 100–300 ms (Beiderman, 1981; Intraub, 1981; Thorpe et al., 1996). This appears reasonable on several grounds. When observers scan visual scenes they usually make saccadic eye movements anywhere from one to four times a second, with the duration of visual fixation occasionally being as brief as 100 ms. Because the retinal image changes with each new visual fixation, perceptual grouping should take place at least as quickly as the interval between saccadic eye movements. Evidence for this comes from experiments in which observers, signaling the presence or absence of an animal in briefly presented scenes, exhibit event-related potential components that correlate with task performance as early as 150 ms after stimulus onset (Thorpe et al., 1996).

Together, these considerations suggest that the neuronal mechanisms responsible for perceptual grouping must operate within specific constraints. The mechanism must be capable of evaluating the relations among visual features and of identifying those combinations that exhibit Gestalt properties. It should be flexible, have a large combinatorial capacity, and be parallel in its organization so that many feature combinations can be

grouped simultaneously. The process must be fast, and should occur within the time available during the course of a visual fixation.

### Potential Mechanisms Underlying Perceptual Grouping

What types of mechanisms might mediate the neuronal operations underlying perceptual grouping? Fortunately, research on the physiology and anatomy of the visual system has been one of the most active areas of neuroscience, so there are several good candidate mechanisms to consider. Here, I will briefly discuss three possibilities and consider their merits as well as their disadvantages.

#### Convergent Hierarchical Coding

The most widely accepted model for feature integration relies on the well-established understanding that visual cortex is organized hierarchically into a collection of distinct areas (Rosenquist, 1985; DeYoe and Van Essen, 1988; Felleman and van Essen, 1991; Sereno and Allman, 1991; Payne, 1993). In its simplest form, the visual cortical hierarchy can be viewed as a series of processing stages, where each stage carries out specialized, parallel operations that depend on the input from earlier stages. This hierarchical processing leads to an increase in the complexity of neuronal representations as the hierarchy is ascended. Evidence for this is revealed by the gradual decrease of retinotopic specificity, the increase in receptive field size, and the dependence of neuronal responses on increasingly complex stimulus features. At the same time, there is substantial evidence that separate cortical areas process specific attributes of visual features, suggesting that the analysis of visual

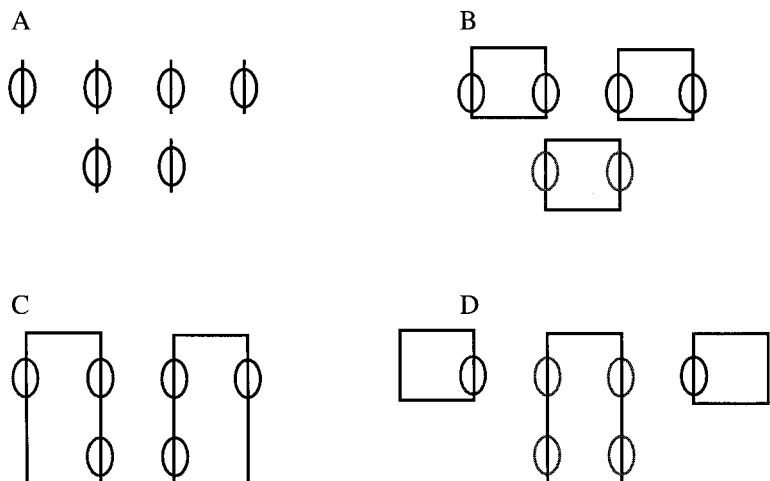

Figure 4. Diagram Illustrating the Requirement for Parallel Grouping and Segmentation

(A) Six hypothetical receptive fields, each tuned to vertical orientation.

(B–D) Three different scenarios in which the grouping criteria change, but the local features stimulating the cells remain relatively constant.

scenes is subdivided (Livingstone and Hubel, 1988; Zeki and Shipp, 1988; Van Essen and Anderson, 1990; Van Essen et al., 1992; Merigan and Maunsell, 1993). In primates, this organization culminates in the broad anatomical and physiological subdivisions of the dorsal and ventral streams, lying in the parietal and inferotemporal (IT) areas, respectively. These regions make fundamental contributions to the spatial localization and recognition of objects (Ungerleider and Mishkin, 1982; Goodale and Milner, 1992; Milner and Goodale, 1993).

This organization, particularly that of the temporal stream, has specific implications for preattentive processing. It suggests that grouping operations may be expressed by the activity of small collections of neurons (by single neurons in the extreme) by virtue of the elaboration of receptive field properties that occurs as the cortical hierarchy is ascended. This concept, most clearly articulated by Barlow (1972) and driven by the receptive field paradigm in visual neuroscience, implies that features and constellations of features are represented by the activity of neurons that receive convergent inputs from populations of neurons at lower levels in the hierarchy (Fujita et al., 1992; Tanaka, 1993). This type of mechanism is attractive for at least three reasons. First, there is a large body of evidence demonstrating that receptive field properties exhibit the requisite increases in complexity and specificity across the cortical hierarchy. At the highest levels, neurons exhibit selective responses to object-like stimuli (Gross et al., 1972; Desimone et al., 1984, 1985; Baylis et al., 1985; Perret, 1987; Fujita et al., 1992; Tanaka, 1993, 1996; Logothetis et al., 1995). Second, the selectivity for complex features is established early on in the time course of responses to stimuli (Rolls and Tovee, 1994). This indicates that the convergence of information, and hence the grouping of features, can satisfy the strict temporal requirements mentioned earlier. Finally, there are a number of studies demonstrating a close correlation between the activity of single neurons and the performance of animal subjects on sensory discrimination tasks (Newsome et al., 1989; Britten et al., 1992, 1996; Parker and Newsome, 1998). The combination of these attributes provides a strong argument that perceptual grouping can be achieved by hierarchical and convergent connectivity.

For a number of reasons, however, this is not likely to be the whole story. Convergent coding mechanisms of this type suffer from what is known as a "combinatorial problem." To appreciate this problem, it is useful to refer to the diagrams shown in Figure 2. In order to build a receptive field to code for the small square in Figure 2A, it would be necessary to send the outputs of the neurons coding for the orientations and positions of the local contours to a common location at a higher stage in the hierarchy. Neurons receiving these inputs could then represent a square at that location because their receptive fields would be organized to respond to the appropriate input. A similar mechanism could be used to represent the other squares in the figure. However, each of the squares includes a contour that lies over a common receptive field (upper left vertical contour). This means that the higher-level neurons, whose receptive fields code for the other squares, would all have to receive input from the neurons activated by the common

vertical contour. One can see that this type of mechanism quickly becomes untenable, when it is realized that the number of objects capable of sharing a common contour is very large. Each neuron would have to send an equally large number of connections to the next successive stage of the hierarchy, leading to an unacceptably large number of connections. Even if such connections could be configured appropriately, similar arguments apply to the number of neurons needed to represent all of the possible feature combinations. A mechanism of this type, in such a simple form, seems unlikely to solve the problem.

#### *Population Coding*

It has been recognized by many investigators that the combinatorial problem can be overcome by a simple modification of the convergent coding scheme outlined above. Rather than represent the integration of features by the activity of a few or even single neurons at specific cortical loci, complex feature combinations could be represented by the activity of a population of neurons distributed within and across levels of the cortical hierarchy (Ballard et al., 1983; Van Essen and Anderson, 1990). In this scheme, each stimulus pattern could be represented by a distinct pattern of firing in a distributed population of cells. Such a coding scheme would greatly increase the representational capacity of the cortical network, because the number of distinct patterns of activity far outstrips the number of neurons available to represent the stimuli. Thus, the combinatorial complexity of the sensory world would no longer pose a problem.

This scenario meshes well with many aspects of the anatomical and physiological organization of visual cortex. The anatomical connectivity within and between different levels of the cortical hierarchy is both divergent and convergent (Felleman and Van Essen, 1991; Rockland and Van Hoesen, 1994; Salin and Bullier, 1995; Levitt et al., 1996). Neurons in a given cortical area send divergent outputs to other areas, enabling the cells in these areas to receive convergent input from many sources. This type of organization provides neuronal populations at the highest levels of the hierarchy with broad access to the entire visual field and the full range of visual feature properties, clearly marking them as candidate areas for feature integration and perceptual grouping. Similarly, there is substantial physiological evidence from both sensory and nonsensory cortical areas that stimuli, as well as motor actions, are represented by distributed populations of cellular activity (Lee et al., 1988; Georgopoulos et al., 1992; Young and Yamane, 1992; Wilson and McNaughton, 1993; Nicolelis and Chapin, 1994; Vaadia et al., 1995; Nicolelis et al., 1998). Thus, on both anatomical and physiological grounds, it appears reasonable that processes involved in sensory representation and perceptual grouping involve distributed neuronal activity.

Attractive though it may be, this model of sensory representation is again incomplete. To illustrate this, first consider a somewhat artificial situation in which a complex 3-dimensional object is presented against a background of uniform luminance and wavelength, a situation not unlike seeing a bird flying on a cloudless day. It is easy to appreciate how such a stimulus could give rise to a unique pattern of activity distributed across

the cortical hierarchy. The situation becomes considerably more complex when two objects are present in the same scene, particularly if they are close to or overlapping with one another. If each object gives rise to what would otherwise be a unique pattern of activity, what would identify the activity of the widely distributed neurons as belonging to one representation or another? Now consider the more common situation of a scene containing multiple objects and backgrounds varying in texture, luminance, and wavelength, and it's easy to see that a real conceptual problem arises. If features and objects are represented solely by the firing of distributed populations of cells, how are the vast numbers of active neurons in the cortical network disambiguated from one another? How can one or more distinct patterns be identified from the many others that are present in the same networks at the same time? This conundrum, first identified and articulated by Milner (1974) and von der Malsburg (1981, 1985), is often referred to as the "superposition problem."

The essence of this problem is one of identification and interference. How are members of a representation identified as belonging to that representation, and how is interference between simultaneous representations avoided? These questions lie at the heart of the binding problem and perceptual grouping. In models of attentional selection, these problems are often dealt with by saying that attention solves the binding and superposition problems by suppressing the activities evoked by all of the unattended features or enhancing the activities evoked by the attended features (e.g., Olshausen et al., 1993). However, this begs the question of how attention could be capable of serially searching all the possible feature combinations in a reasonable amount of time (Milner, 1974). Some form of image segmentation should occur that not only happens prior to attention but also serves to attract it (Neisser, 1967). One possibility is that salient features in an image, such as regions of high contrast or movement, lead to elevated activity, and the population of cells with the greatest activity captures attention (Koch and Ullman, 1985). The problem here is how to define the population. There may be multiple overlapping populations of cells with elevated activity that coexist in the same network. What kind of mechanism could serve to identify the appropriate features as belonging together?

#### *Representation by Assemblies and the Temporal Correlation Hypothesis*

A theoretical resolution of these problems was put forth independently by Milner (1974) and von der Malsburg (1981, 1985) (for related sets of ideas, see also Braitenberg, 1978; Edelman, 1978), which I will refer to as the "temporal correlation hypothesis" (Singer and Gray, 1995). The key insight in each of these models is simple. Given that the activity evoked by the features comprising an object is distributed, some mechanism is necessary to identify the members of a representation as belonging together and to distinguish them from other representations that may be present at the same time. Relying on an earlier set of ideas put forth by Hebb (1949), it was postulated that perceptual grouping and segmentation could be mediated by the formation of cell assemblies. This process was envisioned as occurring in parallel,

such that multiple cell assemblies could be formed simultaneously, one for each set of grouped features. The properties of the cell assembly differed from those postulated by Hebb (1949) in that they were considered to be dynamic entities. The structure of an assembly would be determined not only by the anatomical organization of the cortical network, but it would also be constrained by the Gestalt properties of the stimulus features present in the scene. Because cell assemblies are defined as unitary entities, in which the neurons within an assembly interact more strongly with one another than with neurons outside the assembly (Braitenberg, 1978; Palm, 1981, 1990; Gerstein et al., 1989), this mechanism provided a means for the grouping of distributed activities and avoidance of the superposition problem. The question remained as to what mechanism would drive assembly formation, and what internal dynamic structure of a cell assembly would distinguish it from the other neuronal activity present simultaneously in the cortical network.

The common insight put forth to solve this problem was to define cell assemblies on the basis of the temporal correlation or synchronization of neuronal firing (Milner, 1974; von der Malsburg, 1981, 1985). Because neurons are sensitive to the timing of their synaptic inputs, it was argued that synchronization provided at least two important advantages. It would serve to reinforce the interactions among the members of an assembly and would provide a highly effective neuronal signal to systems responding to the output of an assembly. Although Milner (1974) did not explicitly define the time scale of the neuronal interactions within an assembly, von der Malsburg (1981, 1985) argued that synchronous firing should occur on a time scale of  $<5$  ms. He also postulated a process of fast synaptic modulation, lasting hundreds of milliseconds, in which the strength of synaptic excitation onto a neuron would be transiently enhanced when the synaptic input to a neuron was synchronous with its spike output. This was postulated to provide a positive feedback mechanism to amplify weak correlations of activity. Milner (1974) recognized the need for a reinforcing mechanism and postulated that this function might be implemented through the feedback pathways from higher levels in the cortical hierarchy.

Given that perceptual grouping occurs over a range of spatial scales, both authors recognized the need for an anatomical substrate to mediate horizontal interactions within the cortical network. Milner (1974) postulated the existence of "distance cells" to link separate regions of the visual field, and von der Malsburg (1981) postulated a horizontal fiber system within primary visual cortex that would link populations of cells sensitive to the same categories of local features. In the latter scheme, common features in an image would lead to coactivation of cells with similar receptive field properties. Because of their lateral interconnections, these cells would in turn mutually reinforce one another. The resulting temporal correlations of firing would then be amplified by the fast synaptic modulation. In this way, assemblies could emerge through cooperative interactions, with their spatial structure being determined by both the stimulus as well as the underlying pattern of horizontal connections in the cortical network. (It is

worth noting that at the time these theories were developed very little evidence was available for the existence of horizontal connections in primary visual cortex [Creutzfeldt et al., 1977; Gilbert and Wiesel, 1979], and there was essentially no evidence to suggest that the horizontal connections might link up populations of cells having similar receptive field properties. Both of these phenomena are now firmly established.)

Both authors proposed that this process should have hierarchical depth in the sense that neuronal assemblies would be defined not only within a given cortical area but also across levels in the cortical hierarchy, mediated through both feedforward and feedback pathways. Assembly formation would allow for local relationships to be defined early in the visual pathway, where retinotopic specificity is high, and for more global relationships to be established at higher hierarchical levels that could in turn reinforce the relations established at earlier levels. In this scheme, each set of grouped features in a scene would be defined by the formation of a cell assembly based on the synchronization of neuronal firing among populations of cells distributed within and across different levels of the cortical hierarchy. Different assemblies would be distinguished from one another by the independence of their firing patterns. Thus, multiple, highly salient distributed signals could coexist in the same network of cortical areas at the same time, each providing an independent representation of grouped features that could serve as the basis for attentional selection.

#### *Why Has the Correlation Hypothesis Been So Attractive?*

Although the temporal correlation model provides a number of fundamental advantages over competing theories, it remained an unpublicized theoretical curiosity until experimental evidence began to support some of its basic tenets. Numerous electrophysiological experiments had demonstrated that cortical neurons engage in synchronous firing on a millisecond time scale (Toyama et al., 1981a, 1981b; Michalski et al., 1983; Ts'o et al., 1986; Aiple and Krüger, 1988; Krüger and Aiple, 1988; Ts'o and Gilbert, 1988; Hata et al., 1991; Schwarz and Bolz, 1991). The majority of these studies, however, were conducted as a means for determining the functional connectivity among neurons. This approach was based on studies by Perkel and coworkers, who laid the foundations for interpreting cross-correlation measurements as physiological indications of anatomical connectivity (Perkel et al., 1967; Moore et al., 1970). Many cross-correlation studies were interpreted within this framework, as indicated by the lack of emphasis on the stimulus dependence of correlated activity and the use of pharmacological techniques to enhance neuronal firing rates in the absence of sensory stimulation.

A surge of interest in the correlation hypothesis took place when a series of experiments demonstrated that both short- and long-range synchronous firing in visual cortex were stimulus dependent (Gray and Singer, 1987, *Soc. Neurosci.*, abstract, Gary and Singer, 1989; Eckhorn et al., 1988; Gray et al., 1989). These studies revealed that synchronous firing within and between columns of striate cortex was largely absent during

spontaneous activity and could be evoked by appropriate visual stimulation. The correlated firing was accompanied by a rhythmic modulation of firing probability in the range of 30–60 Hz, suggesting that synchronous activity was an emergent phenomenon resulting from cooperative interactions in the cortical network. These findings were reminiscent of the theoretical predictions of Milner (1974), von der Malsburg (1981, 1985), and others (e.g., Braitenberg, 1978), because they demonstrated that synchronous firing was a transient, stimulus-dependent process. This interpretation stood in marked contrast to the more static notion that correlated firing was primarily the result of direct synaptic connectivity among cells. A further boost to the correlation theory came from the observation that synchronous firing depended not only on the presence of a stimulus but also on its global properties, such as common motion (Gray et al., 1989). Together, these findings led to a wave of new experimental studies and theoretical models (reviewed by Singer, 1993; Gray, 1994; Singer and Gray, 1995), although the latter far outnumbered the former.

What prompted this exuberance (some might say “irrational exuberance”) of experimental and theoretical activity? I believe it can be traced back to widespread dissatisfaction with the conventional paradigm in sensory physiology. For roughly 40 years, much of sensory physiology was based on a common experimental paradigm and the results of experiments were often interpreted within a somewhat narrow theoretical framework. With few exceptions, measurements of neuronal activity were made one cell at a time, and the variability of sensory responses, thought to reflect noise in the system, was removed by averaging, resulting in the conventional peri-stimulus time histogram or PSTH. This provided an accurate measure of a cell's mean firing rate as a function of time but also had the effect of removing much of the evidence of temporal structure in the neuronal activity. As a result, time, and hence neuronal dynamics, was relegated to a back seat in the focus of many researchers. The other major factor was the search for the ever-elusive representation of perceptual features and objects. This search was driven by the implicit assumption that the neural basis of sensory representation could be elucidated by mapping the receptive field properties of cortical neurons at different levels of the cortical hierarchy. If one knew the relationship between mean firing rate and stimulus properties, this would be sufficient to account for sensory representation. The rationale of this approach was clearly articulated by Barlow (1972) in his influential article entitled “Single units and cognition: a neurone doctrine for perceptual psychology.” This approach led to extensive advances in our understanding of the cortical hierarchy but failed to provide an adequate theoretical framework for evaluating neuronal population dynamics. As a result, the dynamic behavior of neuronal populations had to be inferred from the mean firing rates and receptive field properties of single neurons measured one at a time.

The fundamental attraction of the temporal correlation model was that it provided a potential solution to the binding and superposition problems, while retaining all of the advantages inherent in population coding models.

It provided a physiologically plausible theoretical framework to account for the integration of distributed features into an emergent representation, and for distinguishing one representation from another under conditions when they would be present simultaneously. Moreover, it was envisaged as a dynamic process that depends on the properties of the visual features in an image. In this way, assemblies, defined by patterns of synchronous firing, could integrate features flexibly and with large combinatorial capacity. The initial evidence supporting this model unleashed a flurry of experimental and theoretical studies that were not limited to the visual system or notions of perceptual grouping (see Singer, 1999b [this issue of *Neuron*]). These were driven by the concepts of dynamic neuronal assemblies in which sensory, cognitive, and motor events are represented as dynamic patterns of activity in distributed populations of neurons (Vaadia and Aertsen, 1992; Bressler et al., 1993; Abeles et al., 1994; Varela, 1995; Fuji et al., 1996).

#### Evidence for and against the Correlation Hypothesis

An obvious question has arisen in the years since the initial findings supporting the correlation model: does the current body of evidence favor support for or rejection of the hypothesis? Alternatively, perhaps the key experimental tests of the hypothesis have yet to be done? In order to fully address these questions, it is necessary to briefly review the predictions of the theory. Because I have narrowed the scope of the original theories put forth by Milner (1974) and von der Malsburg (1981, 1985), I will limit my review to those predictions relating to preattentive perceptual grouping, first discussing the evidence that supports the predictions, and following with a discussion of evidence that would lead one to reject the hypothesis.

##### *Supporting Evidence*

*Occurrence.* The first and most obvious requirement of the correlation model is that synchronous neuronal firing should occur in the nervous system and in the visual cortex in particular. The plethora of studies over the past 20 years should leave no doubt that this is the case for the visual cortex, and for the nervous system in general (reviewed by Gray, 1994; Singer and Gray, 1995; Usrey and Reid, 1999; Singer, 1999b). Synchronous neuronal activity occurs over multiple temporal and spatial scales in the visual system. It can occur with high temporal precision where coincident spikes occur within 1 ms of each other. This type of synchrony, thought to reflect direct synaptic interactions, is most commonly observed between cells that are in close spatial proximity or that receive direct afferent connections (Toyama et al., 1981a; Usrey et al., 1999). Synchronous firing is also commonly observed at an intermediate time scale in which coincident spikes occur within  $\pm 10$  ms of one another. This type of correlated activity occurs most often in response to sensory stimulation, can be sustained over periods ranging from tens to thousands of milliseconds, and can occur between cells located in the same cortical column, in different columns within the same cortical area, and in different cortical areas, as well as between cells located in the two cerebral hemispheres (Engel et al., 1991b; Singer and Gray, 1995). Because of its properties, this intermediate time

scale of synchronous firing is thought to provide a suitable, but not necessarily the only, substrate for the formation of dynamic cell assemblies. A third form of synchronous firing is commonly observed in which loosely coincident spikes occur within time scales of tens to hundreds of milliseconds of one another (Nelson et al., 1992; Nowak et al., 1995b, 1999). This type of correlated activity, also referred to as rate coherence (Vaadia and Aertsen, 1992), can occur spontaneously or be driven by visual stimulation, and has been observed over spatial scales similar to the intermediate form of synchrony. Taken together, then, the accumulated evidence indicates an abundance of synchronous activity in the visual system.

*Proximity.* Within the context of perceptual grouping, the correlation hypothesis makes a number of specific predictions regarding the properties of synchronous activity. The first of these predicts that synchronous firing should occur when cells are activated by stimulus features that exhibit one or more of the Gestalt grouping properties. This is a strong set of predictions, and each must be considered in turn. Gestalt theory predicts a strong association between features that lie in close proximity. In the context of the correlation model, synchronous firing should therefore fall off with distance in retinotopically organized cortical areas. The accumulated evidence supports this prediction, but the issue has been studied primarily in striate cortex. Here, the results are clear. The incidence and magnitude of synchronous activity drops off with the distance between cells, the largest separation showing positive correlation being  $\sim 10$  mm (Michalski et al., 1983; Ts'o et al., 1986; Ts'o and Gilbert, 1988; Gray et al., 1989; Engel et al., 1990; Schwarz and Bolz, 1991; Livingstone, 1996). These intracortical distances within striate cortex typically correspond to visual field separations of less than  $5^\circ$ . Therefore, it will be interesting to see what type of relationship is present in extrastriate areas of the visual cortex, where receptive fields are larger and the spatial resolution is coarser.

*Similarity.* Another strong prediction of the correlation model is that synchronous activity should occur preferentially when cells are activated by features having similar properties. This should hold for many different feature categories such as orientation, color, and common motion. Here, again, these properties have been investigated primarily in striate cortex, and the bulk of the data relate to the orientation dependence of the interactions. Less information is available on common motion, and even less with respect to color (Ts'o and Gilbert, 1988). With respect to orientation, a number of studies have demonstrated that synchronous firing among cells with nonoverlapping receptive fields tends to occur most often when those cells have similar orientation preferences (Ts'o et al., 1986; Ts'o and Gilbert, 1988; Eckhorn et al., 1988; Gray et al., 1989; Schwarz and Bolz, 1991; Livingstone, 1996), although exceptions to this trend have been observed (Gray et al., 1989; Engel et al., 1990). This relationship is generally thought to reflect the bias for similar orientations in the patterns of horizontal intracortical connectivity in striate cortex (Gilbert and Weisel, 1983, 1989; Blasdel et al., 1992, Soc. Neurosci., abstract; Malach et al., 1993; Levitt et al., 1996; Bosking et al., 1997; Kisvarday et al., 1997; Schmidt et al., 1997). When

the separation between cells is smaller, such that they have overlapping receptive fields (i.e.,  $<2$  mm), the relation between orientation preference and synchronous firing is less clear. Correlated firing occurs with roughly equal probability for all combinations of orientation preference (Gray et al., 1989; Engel et al., 1990; Das and Gilbert, 1999). In the context of the correlation model, this may provide a mechanism for linking contours of different orientation, when the cues for spatial proximity dominate.

*Common Motion.* There have been fewer studies investigating the influence of common motion on synchronous firing, but they tend to confirm the predictions of the correlation model. A prominent effect of common motion was demonstrated in striate cortex by Gray et al. (1989). In two cases, they showed that pairs of cells separated by 7 mm engaged in synchronous firing when activated by bars drifting in the same direction and with the same velocity. This effect was absent when the same two bars drifted in opposite directions, in spite of the fact that both sets of stimuli elicited responses of roughly equal magnitude. A similar effect was demonstrated by Engel et al. (1991a) for cells recorded simultaneously in striate cortex and a motion-sensitive area of extrastriate cortex in the cat. In both of these studies, however, the samples were very small and the effects were measured using recordings of multiunit activity. This raised two concerns: the effect might be rare, and the differences in correlation strength between the two stimulus conditions might stem from the recruitment of different groups of cells during the responses. These criticisms were addressed in a study by Freiwald et al. (1995), who recorded from pairs of single units and demonstrated a similar effect of common motion on synchronous firing. The general trend of these findings was further confirmed by two later studies conducted in the monkey. Livingstone (1996) showed that synchronous firing was greater in magnitude when the stimuli activating the cells moved in the same rather than in opposite directions. Kreiter and Singer (1996) demonstrated an effect of common motion in the middle temporal area (MT) in the alert monkey. They recorded from pairs of cells having partially overlapping or nonoverlapping receptive fields but different direction preferences. When the cells were activated by two bars presented together, each moving over the receptive fields in the preferred direction of the cells, they observed little or no response synchronization. When the same cells were activated by a single contour, moving in a direction intermediate to that preferred by the two cells, they observed strong synchronization. This study provided convincing evidence for the dependence of synchronous activity on coherent motion. Two of the methods employed in this study left room for interpretation, however. The authors recorded multiunit activity in the majority of their measurements, and they selectively sampled only those pairs of recordings that exhibited synchronous activity to at least one stimulus condition. Thus, in spite of a strong effect, it is uncertain what percentage of cells within MT participate in this phenomenon.

*Continuity and Segmentation.* Aside from the issues of proximity and similarity, the correlation model also makes strong predictions regarding figural continuity, closure, and segmentation. Each of these properties

provides strong cues for perceptual grouping. For example, when features, such as oriented contours, belong to a contiguous figure or one that is bounded on all sides, the model predicts that activity evoked by those features should be synchronous, even if they differ in orientation. Similarly, if more than one contiguous or closed figure is present in an image, the patterns of synchronous firing evoked by each figure should be independent of one another. These predictions have not been extensively tested, but a few experiments deserve mention. In the studies of Gray et al. (1989) and Freiwald et al. (1995) mentioned above, the strongest synchronization was observed when the cells were activated by continuous collinear contours. In a separate study of segmentation, Engel et al. (1991c) demonstrated that cells in striate cortex form separate synchronous assemblies when two drifting bars are presented together but move in orthogonal directions over the same region of the visual field. This study provided support for a key prediction of the correlation model. However, all of the measurements were made using multiunit activity, and the different stimuli used in the study led to marked differences in the firing rates of the cells. This raised the concern that the observed changes in synchronization might be due to the recruitment of different populations of cells as the stimulus was changed. Taken together, the results of these three studies support a role for synchronization in contour integration and feature segmentation, but further work is necessary to rigorously test the predictions.

*Correlates with Perception.* The other major prediction of the correlation model is that the patterns of synchronous firing evoked by perceptually grouped stimuli should correlate with an animal's performance on a perceptual discrimination task. Unfortunately, direct tests of this fundamental prediction have been few and limited in scope (de Oliveira et al., 1997; Fries et al., 1997; Lamme and Spekreijse, 1999). Thus, at present, the most important predictions of the theory are the ones for which the least experimental evidence is available. However, convincing evidence has been obtained for an indirect correlation between response synchronization and behavioral responses during interocular rivalry (Fries et al., 1997). In this study, recordings of multiunit activity were made from areas 17 and 18 in alert, strabismic cats while the animals viewed drifting gratings presented to either one or both eyes. The strabismus, induced at 3 weeks of age, shifted the distribution of ocular dominance in the adult animals so that the cortical neurons were only responsive to either the dominant or the non-dominant eye. During binocular stimulation, each eye viewed a grating of the same orientation but drifting in opposite directions. This led to a rivalrous condition in which the eye mediating detection of the stimulus, usually the dominant eye, controlled the direction of optokinetic nystagmus (OKN). Making use of this effect, Fries et al. (1997) showed that synchronous activity, during rivalrous stimulation, was enhanced among the neurons supporting OKN and reduced among the neurons that were not supporting OKN. This effect occurred with no detectable differences in firing rates across the stimulus conditions they employed. This result provides the interesting, if somewhat complex, demonstration that the magnitude of synchronous firing, and not mean neuronal

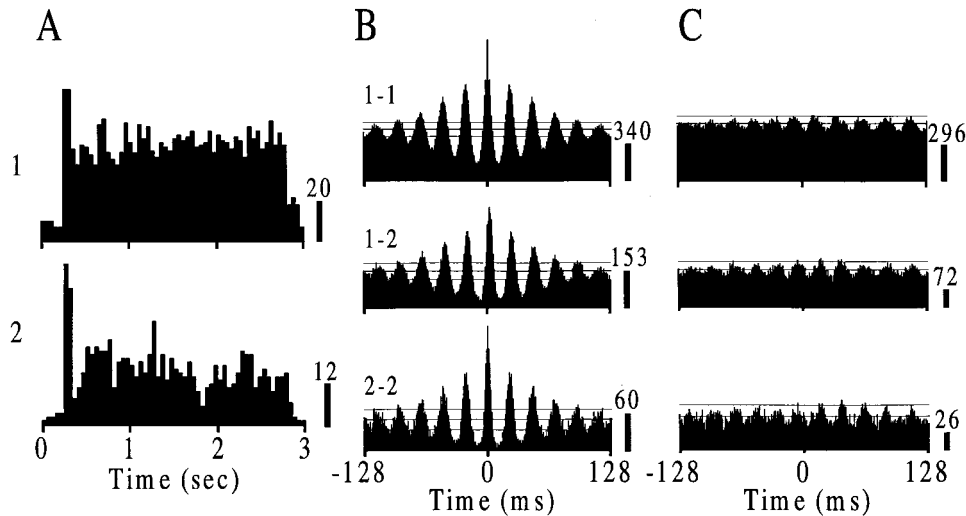

Figure 5. Stimulus-Evoked, Synchronized Oscillatory Activity in Striate Cortex of an Alert Macaque Monkey

(A) PSTH of multiunit activity recorded on two adjacent electrodes (1 and 2) separated by 300  $\mu\text{m}$ . The cells had overlapping receptive fields and preferred the same orientation. They were coactivated by a single drifting grating of optimal orientation and direction. (B) Auto- (1-1 and 2-2) and cross-correlation (1-2) histograms computed from the two spike trains during the response to the stimulus. (C) Auto- and cross-correlation histograms computed from the same data after shuffling the spike trains by one stimulus period. The diminished amplitudes of the peaks in these histograms demonstrates that the synchronous rhythmic firing is not time-locked to the stimulus.

firing rate, correlates with the animal's perception of the stimuli.

While the results of this study provide support for the correlation hypothesis, several points deserve further discussion. First, the measured relations between perception and synchronization were indirect. OKN was not assessed during the periods of data collection, and thus the animal's perception of the stimuli could only be inferred from the previous behavioral tests. Similarly, while the eye that supports perception during rivalry determines the direction of OKN, this assay of behavior is limited in that it does not allow for a direct measure of perceptual discrimination. Finally, the experiments provide support for the hypothesis under conditions in which the normal physiology and anatomy of the cortex are perturbed (Löwel and Singer, 1992). It would be useful to determine if similar effects occur in animals with normal binocular vision.

#### *Contradictory Evidence*

Experimental evidence favoring a rejection of the correlation hypothesis has come from a variety of sources, but it has been more limited in scope than the supporting evidence. Critics of the hypothesis have largely based their arguments not on the validity of the contradictory evidence, but rather on criticisms of the supporting evidence and on arguments of the implausibility of the model. Here, I will focus on three sources of experimental evidence that contradict the claims of the correlation model. I will discuss the criticisms of the supporting evidence and issues of implausibility later.

#### *Incidence and Properties of Neuronal Oscillations.*

When the experimental evidence supporting the correlation hypothesis was first reported, considerable emphasis was placed on the finding that synchronous firing in striate cortex often occurred during prominent oscillations of firing probability in the  $\gamma$  (30–60 Hz) frequency band (Gray and Singer, 1987, Soc. Neurosci., abstract;

Gray and Singer, 1989; Eckhorn et al., 1988; Gray et al., 1989, 1990; Engel et al., 1990). This led to a number of studies on the properties of stimulus-evoked  $\gamma$  band activity. Implicit in these studies was the notion that much could be learned about synchronization by elucidating the properties of oscillatory activity and its stimulus dependence. Several published studies favored rejection of the hypothesis on the basis that oscillatory activity was either not evident or did not exhibit the requisite stimulus dependence. Tovee and Rolls (1992a) reported that neuronal activity in the inferotemporal (IT) cortex of alert monkeys showed no signs of  $\gamma$  band oscillations when the cells were activated by stationary stimuli. Because IT cortex is considered to play a prominent role in object recognition, and thus feature integration, they argued that the absence of  $\gamma$  band activity favored the rejection of a synchronization-based mechanism for feature integration (Tovee and Rolls, 1992b; see also Engel et al., 1992a). A similar argument was put forth by Young et al. (1992) (see also discussion in Shastri and Ajanagadde, 1993) on the basis of measurements in striate cortex and area MT of anesthetized monkeys and area IT of alert monkeys. They found little or no evidence for  $\gamma$  band activity in any of the three areas, even though they made explicit efforts to replicate the methods of previously published observations (Engel et al., 1990). They argued that  $\gamma$  band activity and, by extension, synchronous activity were phenomena limited to the cat and should therefore not be candidates for a general mechanism contributing to mammalian visual processing. This argument may have held weight, given the demonstration that long-range, stimulus-dependent synchronization in striate cortex of the cat is closely linked to rhythmic firing in the  $\gamma$  frequency band (König et al., 1995). But it was demonstrated in several later studies that synchronous  $\gamma$  band activity is a robust property of neuronal responses in areas V1

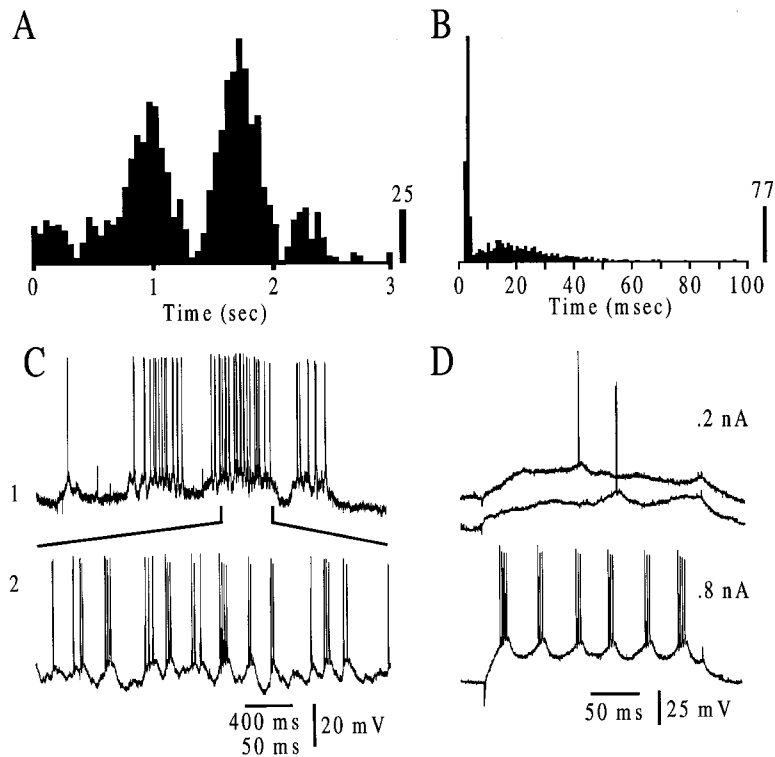

Figure 6. Activity Recorded from an Intrinsically Oscillatory (Chattering) Cell in Cat Striate Cortex in Response to Visual Stimulation and Intracellular Depolarizing Current Pulses (A) PSTH recorded in response to 20 presentations of an optimally oriented, drifting light bar presented to the contralateral eye. (B) The interspike-interval histogram (ISIH) computed from the spike trains sampled during the visual response. Note the characteristic bimodal shape of the distribution reflecting the intervals occurring within and between bursts. (C) Membrane potential of the cell recorded during a single presentation of the stimulus. Trace 1 shows the complete 3 s trial. Trace 2 shows an expanded view of the activity during the peak of the visual response. (D) Responses of the cell to two different levels of depolarizing current pulses. The cell shows no evidence of membrane potential oscillations when depolarized near the firing threshold (upper two traces). When the current intensity is increased to depolarize the cell well beyond firing threshold, a pronounced membrane potential oscillation is evoked, having a frequency near 30 Hz. Adapted from Gray and McCormick (1996).

and V2 of the alert (Figure 5), as well as anesthetized, monkey (Eckhorn et al., 1993; Frien et al., 1994; Friedman-Hill et al., 1995, *Soc. Neurosci.*, abstract; Gray et al., 1995, *Soc. Neurosci.*, abstract; Livingstone, 1996).

In spite of these later observations, there continues to be substantial debate about the prevalence and magnitude of  $\gamma$  band oscillatory activity and neuronal synchronization in the primate visual cortex (for examples, see Kreiter and Singer, 1992, 1996; Bair et al., 1994). Much of this debate is based on anecdotal reports at conferences or on unpublished observations alluded to in the literature. It seems reasonable to suppose that these divergent viewpoints may be compatible, if one considers the possibility that sampling biases and methodological differences contribute to the variations in results. Effects of this type may be particularly acute in the striate cortex, which contains many different cell types and a complex laminar and tangential organization. Similarly, differences in visual stimulation or analysis methods may lead to selective enhancement or suppression of rhythmic and/or synchronous activity (Gray and Viana Di Prisco, 1997). Each of these factors must be taken into account before firm conclusions can be reached.

In another set of experiments, Ghose and Freeman (1992) argued that synchronization-based grouping in cat striate cortex is not plausible, because  $\gamma$  band oscillatory activity is not stimulus dependent. Two lines of evidence figured prominently in their conclusion. They showed that oscillatory firing in striate cortex was strongest at threshold levels of stimulus contrast, indicating that it was occurring spontaneously and did not depend on visual stimulation. This line of reasoning was supported by separate measurements made in the lateral geniculate nucleus (LGN) of the thalamus. They

found pronounced  $\gamma$  band oscillations of activity in the LGN that occurred spontaneously and were in some instances suppressed by visual stimulation. From this, they concluded that cortical oscillations were driven by spurious correlations of spontaneous oscillatory activity in the LGN (Ghose and Freeman, 1992, 1997). Thus, not only was cortical oscillatory activity thought to be independent of visual stimulation, it might also be generated primarily by inputs from the LGN.

Several lines of evidence, however, argue for an alternative interpretation of these findings. Gray and Viana Di Prisco (1997) recorded neuronal activity in striate cortex of alert cats and found that oscillatory firing was stimulus dependent and rarely present in the absence of visual stimulation. They applied the analysis methods used by Ghose and Freeman (1992) and found that these techniques led to an artifactually high incidence of oscillatory activity. In another set of experiments, Gray and McCormick (1996) identified a population of neurons in cat striate cortex that exhibit oscillatory firing patterns generated by intrinsic cellular mechanisms (Figure 6). This finding argues for an intracortical contribution to the generation of  $\gamma$  band activity. Finally, several studies have now demonstrated that the robust oscillatory activity observed in the LGN by Ghose and Freeman is driven by retinal input (Laufer and Verzeano, 1967; Neuenschwander and Singer, 1995; Neuenschwander et al., 1999), occurs in a frequency range that is significantly higher than that commonly observed in striate cortex (Ito et al., 1994, *Soc. Neurosci.*, abstract; Neuenschwander and Singer, 1995), and is only transiently synchronized to cortical activity in area 18 (Castelo-Branco et al., 1998; Herculano et al., 1999). Thus, contrary to the arguments put forth by Ghose and Freeman (1992, 1997), these findings indicate that cortical  $\gamma$  band activity arises

predominantly through intracortical interactions and is not driven by the higher-frequency oscillations generated in the retina.

A general point should also be made regarding the studies considered in this section: although studies of this type are useful in elucidating the properties and mechanisms of oscillatory activity, they are not sufficient to address the fundamental predictions of the correlation hypothesis. For this, experiments must be designed that rely on the measurement of neuronal activity at more than one site simultaneously. In this way, direct measurements of synchronization can be made without having to speculate about the properties of synchrony from single-unit recordings (Engel et al., 1992a).

*Synchronization in a Motion Discrimination Task.* Another source of evidence arguing against the correlation hypothesis has come from a recent study of correlated activity in extrastriate cortex (de Oliveira et al., 1997). These authors measured the activity of small groups of neurons, located within 900  $\mu\text{m}$  of one another, in MT and the medial superior temporal area (MST) of monkeys, while the animals performed a simple direction discrimination task. The animals had to identify the direction of motion of a grating stimulus presented at various levels of contrast. Neuronal activity was recorded before and during the presentation of the stimuli, and cross-correlograms were calculated between all combinations of recorded cells. Interestingly, a high incidence of synchronous firing was found prior to the presentation of the stimulus. When the stimulus appeared, the firing rates of the cells increased, but the synchronization of the activity was reduced in a contrast-dependent manner. High-contrast stimuli that were easily discriminated resulted in a complete suppression of correlated firing. It was concluded that synchronous activity does not convey information about stimulus direction and therefore does not contribute to the direction discrimination task.

These conclusions appear sound and the evidence convincing, but there are also striking differences with earlier studies that need to be resolved. In contrast to the results of de Oliveira et al. (1997), Kreiter and Singer (1992, 1996) demonstrated that synchronous activity in area MT is visually driven and depends on the properties of the stimuli. They used drifting bars rather than gratings, but their animals were not engaged in a discrimination task and were only required to maintain visual fixation. This suggests that the attentive state of the animals in the study of de Oliveira et al. (1997) provides the most likely explanation for the different results. It is striking that attentive expectation might produce such a clear difference, particularly given the large body of evidence demonstrating the stimulus dependence of synchronous activity in other visual cortical areas (Singer and Gray, 1995; Usrey and Reid, 1999). However, neuronal synchronization has been shown to correlate with attentive behavior in other sensory and motor systems (Rougeul et al., 1979; Bouyer et al., 1981; Sanes and Donoghue, 1993; Murthy and Fetz, 1996a, 1996b). Therefore, the results of de Oliveira et al. (1997) must be taken seriously as evidence contrary to the correlation hypothesis. Further studies will be required to resolve the differences.

*A Direct Test of the Correlation Hypothesis.* Although

many arguments and claims have been put forth to reject or support the correlation hypothesis, only one published study has carried out a direct test of several of the key predictions of the model (Lamme and Spekreijse, 1999). In order to place the results of this experiment in context, it is worthwhile to briefly review these predictions. According to the arguments put forth here and elsewhere (Milner, 1974; von der Malsburg, 1981, 1985; Singer, 1993; Singer and Gray, 1995; Roelfsema et al., 1996), the perceptual grouping of features in an image should be directly correlated with the probability and strength of synchronous firing of the neurons responding to those features. The activity of cells responding to other features should be temporally independent of the synchronously firing ensemble. For these predictions to be tested rigorously, it is necessary that the correlation measurements be made in an alert animal while it is performing a perceptual grouping task.

Lamme and Spekreijse (1999) recorded multiunit activity from chronically implanted electrodes while the animals performed a simple texture segregation task. The stimuli consisted of texture patterns composed of dense, uniformly oriented line elements or moving random dot patterns. The figures, defined by a difference in orientation or motion direction with respect to the background, were highly salient. Once the receptive field positions were mapped for a given pair of recordings, the stimuli were constructed to enable the testing of three predictions. On one set of trials, the figure was positioned over both receptive fields of a pair. In this condition, the cells should synchronize their activity. On a second set of trials, the figure was positioned to cover one receptive field, while the other receptive field was covered by the background. In this condition, no synchronization should be observed. And on a third set of trials, the figure was positioned so that both fields were covered by parts of the background. The prediction of the correlation hypothesis is less clear in this case, but given that the background pattern was highly coherent, one might expect to see correlated activity.

The results of these experiments were fairly clear. There was no significant difference in the magnitude of synchronization across the three stimulus conditions when the population of measurements was compared, leading the authors to conclude that response synchronization does not correlate with texture segregation. This seems like a reasonable interpretation of the data and may be correct. However, a closer look at the details of the experimental design and the data analysis reveals another story. There are three key points that need to be made. First, the local properties of the stimuli activating the cells were changed substantially across stimulus conditions. When the figure was presented over both receptive fields, each cell was stimulated by the same orientation or motion direction. But when the figure was shifted in position, so that it covered one field and the background covered the other field, the local orientation or direction of motion stimulating one of the cells was now different by either 20° or 90° for the oriented texture, or 180° for the drifting dots. Although an attempt was made to counterbalance this effect, this is clearly a major change for neurons in V1 that are known to be selective for stimulus orientation and direction of motion. Second,

the neuronal recordings were composed of broadly tuned multiunit signals obtained from chronically implanted electrodes. The neuronal responses displayed very weak orientation selectivity, suggesting that signals were being sampled from a comparatively large volume of cortical tissue. This means that when the local stimulus orientation or motion direction was changed, the signals at each site continued to show vigorous responses because different sets of neurons were being recruited. A condition of this sort makes interpretation of the cellular interactions difficult at best, because the population of active cells is changing as the stimulus changes. Finally, it is doubtful whether the neuronal activity displayed synchronous firing under any of the stimulus conditions. The published cross-correlograms exhibit relatively broad peaks (20–50 ms) centered at zero time lag, an effect that is consistent with synchronized activity at a time scale in the tens of milliseconds. But if one inspects the PSTHs, it is clear that the cells respond to the stimuli with an initial, transient burst of activity followed by a much lower and sustained level of firing throughout the trials. This type of covariation in the rate and latency of neuronal responses has recently been demonstrated to lead to correlation peaks of the type just described (Brody, 1999a, 1999b). Thus, it is possible that the published cross-correlations in firing do not reflect true synchronization, but a common temporal envelope in the cellular responses. Needless to say, a result of this type would also provide evidence contrary to the theory but of a less convincing nature than that claimed by the authors.

Given these considerations, what conclusions can be reached from this experiment? First, the results do not provide a basis for rejecting the correlation hypothesis. They provide limited negative evidence for a phenomenon that is intrinsically difficult to observe. Second, the study reveals certain aspects of an experimental design that are necessary for a rigorous test of the hypothesis. The local properties of the stimulus should remain relatively constant, in order to maintain comparable firing rates, while changes in the relations among features should yield distinct perceptual differences. When possible, recordings should be made of single-unit activity to facilitate the interpretation of the data. And appropriate analytical tools should be applied to rule out spurious sources of correlation when the neuronal responses themselves are nonstationary.

#### **Why Has the Correlation Hypothesis Been So Controversial?**

At the time of its inception, the correlation hypothesis put forth by Milner (1974) and von der Malsburg (1981, 1985) was based largely on theoretical considerations, with very little reliance on experimental evidence to support its claims. Drawing on the concepts of Hebbian cell assemblies (Hebb, 1949; Braitenberg, 1978), the model postulated a mechanism to solve several inherently difficult problems originating from perceptual psychology (Neisser, 1967) and theories of representation in artificial networks (Minsky, 1961; Arbib, 1964). In this context, the theory remained largely uncontroversial, but didn't gather much attention either. The status of the theory changed dramatically when experimental evidence provided support for some of its basic tenets (Gray and

Singer, 1987, Soc. Neurosci., abstract; Gray and Singer, 1989; Eckhorn et al., 1988; Gray et al., 1989, 1990; Engel et al., 1990), whereupon it was rapidly embraced by some and hotly disputed by others. What factors spurred the resulting debate, which has continued unabated into the present? I believe that the origins and current basis of the controversy can be traced to four sources.

#### ***Interpretation, Emphasis, and Speculation***

Following the early experimental studies claiming support for the correlation hypothesis, several things happened which shaped the debate of the issues. First, the robust, stimulus-dependent synchronization of activity within (Gray and Singer, 1987, Soc. Neurosci., abstract; Gray and Singer, 1989; Gray et al., 1989; Engel et al., 1990) and between (Eckhorn et al., 1988) cortical areas was interpreted as evidence for a mechanism underlying perceptual grouping in the visual system. This bold claim received widespread attention from experimentalists and theoreticians alike (Kammen et al., 1989; Sporns et al., 1989; Stryker, 1989; Baldi and Meir, 1990; Schuster and Wagner, 1990; Sompolinsky et al., 1990). Others argued that the results were preliminary—perhaps even interesting and deserving of further study, but not yet warranting such claims. Second, the early studies revealed a phenomenon new to the visual cortex, stimulus-evoked high-frequency oscillations of firing. This phenomenon was attributed with particular significance as a mechanism to facilitate synchronization (Eckhorn et al., 1988; Gray et al., 1989), which led to a large number of theoretical investigations involving the analysis of networks of coupled oscillators (Baldi and Meir, 1990; Niebur et al., 1990; Schuster and Wagner, 1990; Sompolinsky et al., 1990). The focus on oscillations naturally led to an emphasis on phase and frequency as coding parameters, which had its own set of implications. Now the interactions between neuronal populations could potentially be reduced to a couple of parameters, making it mathematically attractive. This in turn raised questions as to how many assemblies could coexist in the same network given the limited number of frequencies and phases (Lisman and Idiart, 1995); it even began to appear as though some might take the analogy to the FM radio seriously (Hoppensteadt and Izhikevich, 1998). Third, two influential studies were published that claimed a role for synchronous oscillations in visual attention and conscious experience (Crick and Koch, 1990a, 1990b). In spite of their clearly speculative nature, these manuscripts attracted further widespread interest. Thus, from a limited number of observations, the correlation hypothesis was expanded far beyond its original scope. The speculative nature of the dialog no doubt raised the blood pressure of some.

#### ***Difficulties with Replication***

Another source of controversy surrounding the correlation hypothesis stemmed from the reported difficulties in replicating some of the original experimental findings. As mentioned earlier, these reports either failed to find evidence of oscillatory activity in the primate visual system (Tovee and Rolls, 1992; Young et al., 1992; Bair et al., 1994), or reported oscillatory activity that was not stimulus dependent (Ghose and Freeman, 1992). In the years since, much of this debate has been cleared up

by the demonstration that synchronous oscillatory activity is stimulus dependent and readily apparent in the striate cortex of monkeys as well as cats (Eckhorn et al., 1993; Fries et al., 1994; Friedman-Hill et al., 1995, Soc. Neurosci., abstract; Gray et al., 1995, Soc. Neurosci., abstract; Livingstone, 1996; Fries et al., 1997; Gray and Viana Di Prisco, 1997). This has shifted the debate from whether these phenomena occur to whether they are of functional importance. However, anecdotal and unpublished reports continue to persist that oscillatory activity is absent or hard to find. Unless findings of this sort are published, these accounts are likely to have little impact other than to fuel the debate.

It is interesting to note that much of the debate surrounding the prevalence and properties of oscillatory activity had little to do with the original formulation of the correlation hypothesis. This debate owed its existence to the emphasis placed on oscillatory firing by the early experimental and theoretical studies. Although current formulations of the correlation hypothesis continue to favor a mechanistic role for oscillatory activity, measuring the properties of oscillatory firing one cell at a time is insufficient for testing the key predictions of the hypothesis. Synchronous activity exists in many forms and can only be assessed by recording from at least two cells simultaneously.

#### *Physiological Plausibility*

In recent years, a new challenge to the correlation hypothesis has been put forth. Powerful arguments have been raised on cellular and biophysical grounds to claim that a synchronization-based mechanism for solving the binding problem is physiologically implausible (Shadlen and Newsome, 1994, 1998; Shadlen and Movshon, 1999 [this issue of *Neuron*]). The essence of this argument is that cortical neurons themselves suffer from a binding problem of sorts (Shadlen and Newsome, 1998). A typical cortical neuron receives  $\sim 5000$  synaptic inputs (Braitenberg and Schuz, 1991),  $\sim 80\%$  of which are excitatory, and at least half, if not more, of these inputs come from other cortical neurons within a radius of  $\sim 200 \mu\text{m}$ . Because of columnar organization, these nearby neurons generally have similar functional properties. Thus, any stimulus that excites one neuron is likely to excite a large number of adjacent neurons that provide input to it. Visual cortical neurons excited by a sensory stimulus usually exhibit firing rates in the range of 10–100 spikes per second, and the efficacy of excitatory synaptic inputs onto cortical neurons ranges from 0.1 mV to 1.0 mV (Mason et al., 1991; Nicoll and Blakemore, 1993; Thomson and West, 1993; Matsumura et al., 1996; Thomson and Deuchars, 1997). These considerations raise a substantial problem when neurons operate within what Shadlen and Newsome (1998) call a “high input regime”: how can a neuron engage in selective synchronous interactions with a subset of its inputs when a large percentage of all the cell’s inputs are active and synchronous? According to Shadlen and Newsome (1994, 1998) (see also Shadlen and Movshon, 1999), this scenario presents an insurmountable problem for any mechanism that relies on a temporal patterning of spike activity, synchronous assemblies included.

At first glance this argument appears articulate, solid, and well grounded. In fact, it may even leave those with an interest in temporal correlation feeling as though they

are pursuing the wrong questions. But closer scrutiny reveals a few weaknesses in the edifice. First of all, the widespread existence of many different forms of temporal patterning and synchronization in the nervous system is empirical proof that the obstacles posed by the “high input regime” are overcome, sometimes with surprising effectiveness (for examples, see Gray, 1994; Singer and Gray, 1995; Usrey and Reid, 1999; see also Singer, 1999b). But how could this be the case, if neurons don’t possess the mechanisms to select synaptic inputs on the basis of their timing? Another large body of evidence appears to suggest otherwise. There are an abundance of cellular mechanisms that can contribute to the temporal structure of neuronal activity. Although the examples are numerous, it is worth considering a few of them in detail to make the point.

The first of these to consider is inhibition. Although Shadlen and Newsome (1994, 1998) treat inhibition as providing a balancing function to stabilize network activity, there is extensive evidence demonstrating that inhibition can also shape the temporal structure of neuronal activity on a millisecond time scale (Freeman, 1975; Buzsaki et al., 1983; Llinas et al., 1991; Lytton and Sejnowski, 1991; Wilson and Bower, 1992; van Vreeswijk et al., 1994; Bragin et al., 1995; Cobb et al., 1995; Whittington et al., 1995; Ylinen et al., 1995; Bush and Sejnowski, 1996; Plenz and Kitai, 1996; Traub et al., 1996; Wang and Buzsaki, 1996; Chrobak and Buzsaki, 1998; Pauluis et al., 1999). One consequence of inhibition is that excitatory synaptic inputs arriving during its occurrence are less efficacious in activating the postsynaptic cell because of the shunting and hyperpolarizing effects of the inhibitory potentials.

Intrinsic voltage-gated conductances provide another class of mechanism capable of shaping the temporal structure of neuronal activity (Llinas, 1988). It is now well established that cortical neurons exhibit a variety of distinct firing patterns in response to depolarizing inputs (Connors et al., 1982; McCormick et al., 1985; Connors and Gutnick, 1990; Gray and McCormick, 1996; Steriade et al., 1998). These patterns range from tonic firing with varying rates of accommodation, to the generation of bursts and intrinsic oscillations. A variety of voltage-gated, dendritic, and somatic currents underlie these phenomena (Johnston et al., 1996; Yuste and Tank, 1996), including outward  $\text{K}^+$  currents that result in afterhyperpolarization or pacemaker activity (Storm, 1990; Hoffman et al., 1997; Luthi and McCormick, 1998) and inward  $\text{Na}^+$  and  $\text{Ca}^{2+}$  currents that can amplify synaptic inputs (Schwindt and Crill, 1995; Stuart and Sakmann, 1995; Margulis and Tang, 1998), produce rebound excitation, or evoke  $\text{Ca}^{2+}$ -dependent action potentials (Schiller et al., 1997). Each of these currents exhibits distinct voltage- and time-dependent properties; thus, their contribution to the membrane potential of a cell will depend not only on the instantaneous voltage but also on the time course of the voltage change.

Some of these conductance mechanisms can have profound influences on the excitability of cortical neurons by enhancing synaptic inputs in a time-dependent manner. For example, Larkum et al. (1999) have recently shown that excitatory dendritic synaptic input, coincident within a few milliseconds of back-propagating  $\text{Na}^+$  action potentials, facilitates the generation of dendritic

Ca<sup>2+</sup> spikes. Margulis and Tang (1998) have shown that coincident excitatory dendritic input leads to supralinear summation that depends on voltage-gated Na<sup>+</sup> currents. Volgushev et al. (1998) demonstrated that the sensitivity of cortical neurons to weak excitatory synaptic input depends precisely on the phase of subthreshold oscillations of membrane potential. Azouz and Gray (1998, Soc. Neurosci., abstract) have found that the action potential threshold in visual cortical neurons recorded in vivo is inversely correlated with the rate of membrane depolarization preceding a spike. These findings demonstrate that cortical neurons possess a variety of voltage-gated inward currents that act postsynaptically to amplify the response of neurons to synchronous synaptic inputs.

Other conductance mechanisms, such as those responsible for generating rapid burst discharges (Traub et al., 1991; Rhodes and Gray, 1994; Gray and McCormick, 1996), may act indirectly to facilitate synaptic transmission in a time-dependent manner. The rapid firing within a burst can lead to temporal summation postsynaptically (Miles and Wong, 1986) and transiently increase the probability of neurotransmitter release (Thomson et al., 1993; Stevens and Wang, 1995). Such a mechanism ensures that bursts, rather than single spikes, will be more effective in mediating synaptic transmission and thus driving the postsynaptic neuron (Gray and McCormick, 1996; Lisman, 1997; Wang, 1999). Moreover, when burst firing occurs synchronously in a population of cells, the efficacy of the resulting synaptic input is likely to be much greater than that occurring among cells firing trains of uncorrelated spikes (Gray and Viana Di Prisco, 1997).

Together, these and other studies demonstrate that intrinsic voltage-gated conductances can regulate the time course and pattern of spike activity, contribute to the effectiveness of synaptic transmission, and endow neurons with an exquisite sensitivity to the timing of their synaptic inputs. In this context, it no longer seems reasonable to think of cortical neurons as integrate-and-fire devices that accumulate input over a time course that is determined by their passive membrane time constant. The time constant itself changes continuously with variations in membrane conductance resulting from synaptic input (Borg-Graham et al., 1996, 1998; Koch et al., 1996). Therefore, conclusions regarding the timing of neuronal activity that are based on such assumptions are likely to be wrong.

#### *Paradigmatic Differences*

On a final note, it should be pointed out that some hypotheses—and the correlation hypothesis is no exception—meet resistance because they represent a significant deviation from a widely accepted theoretical framework. As mentioned earlier, much of cortical physiology has been dominated by the view that cortical function can be elucidated by measuring the mean firing rates of neurons one cell at a time. Temporal fluctuations of activity are often considered to be noise obscuring a signal. This view provides a simple and tractable framework in which the problems of neural coding can be reduced to the counting of spikes. This is very attractive, given the difficulties associated with measuring the activity of even small groups of neurons. If, on the other hand, perceptual phenomena result from the dynamic and nonstationary interactions of large populations of

neurons, controlled by a myriad of nonlinear cellular mechanisms, many of the conventional ways of thinking about cortical organization and measuring its properties will have to change. This argument has no direct bearing on the validity of the correlation hypothesis; however, it may help to account for some of its controversial nature.

#### **Future Experimental Tests of the Correlation Hypothesis**

If the correlation hypothesis, as I have outlined it, is to survive as a viable model of a mechanism contributing to perceptual grouping and segmentation, it will have to withstand a rigorous test of its predictions. What sort of experiment could serve as an adequate test of the hypothesis? If the outcome of an appropriate experiment were positive, what form would the resulting evidence take? Put another way, what type of evidence would satisfy the critics of the theory? Perhaps equally important, what type of evidence would favor a definitive rejection of the hypothesis? This latter issue is difficult to address, because negative evidence is inherently problematic. One can easily resort to a variety of claims to discount it. Here, I will attempt to outline a specific set of criteria that an experimental paradigm must meet to provide a rigorous test of the hypothesis, as I have stated it. I will also discuss what form the evidence might take that would be consistent with a positive outcome for such an experiment.

One question to ask is where to look. There are many areas of visual cortex that no doubt play an important role in perceptual grouping. And good arguments can be made for a number of areas as the appropriate candidate. For several reasons, primary visual cortex is as good a place as any. First, it is well established that striate cortex exhibits robust, stimulus-dependent synchronous activity over a range of spatial and temporal scales. Second, anatomical studies have revealed a rich network of horizontal and feedback connections within striate cortex that could mediate grouping functions (Rockland and Lund, 1982; Gilbert and Wiesel, 1983, 1989; Malach et al., 1993; Levitt et al., 1996; Bosking et al., 1997; Schmidt et al., 1997). And third, a variety of physiological studies in striate cortex have provided evidence for contextual effects related to perceptual grouping (Li and Li, 1994; Kapadia et al., 1995; Lamme, 1995; Polat et al., 1995; Sillito et al., 1995; Zipser et al., 1996; Levitt et al., 1997; Ito and Gilbert, 1999).

Another question to address is what type of stimulus and task should be employed. Here, the answer is fairly clear. The stimuli should be composed of a collection of features that pop out preattentively from a background on the basis of their Gestalt properties. Ideally, these features would contain multiple cues for grouping such as continuity, closure, and common motion. This would make them highly salient and easily detectable as a figure. The stimuli should be constructed so that the local features activating the cells can be held relatively constant, while the relations between the features can be modified to change the global properties of the image. This would be essential, so that the salience of a figure with respect to the background could be varied along a continuum, thereby varying the difficulty of the task. The task itself must require the active participation

of the animal, so that one could be relatively certain that the animal sees and responds to the figure. This could be attained by simply having the animal detect the presence of a figure by looking at it, or by performing a discrimination task. Having control over the salience of the figure would then enable the experimenter to evaluate the relation between neuronal activity (i.e., temporal correlations of activity) and behavioral performance. Finally, the measurements of neuronal activity must be made at the same time that the animal is performing the task. This is the only way to establish a convincing correlation between neuronal activity and behavior.

If such an experiment were conducted, what type of evidence would constitute convincing support for the correlation hypothesis? Here, the answer is straightforward in some sense, but it may be important to establish criteria that are not too rigid in order to accommodate unexpected observations. The simplest prediction would be as follows: two neurons should exhibit *synchronous firing* when they are activated by *different parts* of a *perceptually segmented* figure. When the position of the figure is changed, so that one of the neurons is activated by an element of the background and the other by an element of the figure, their activity should be temporally independent. In the former case, the strength and/or probability of synchronous firing should covary with the salience of the figure and with the behavioral performance of the animal.

While this prediction appears definitive, it is important to clarify a few of its key components. First, what is meant by synchronous firing? What are the appropriate time scales, latencies, and durations of synchronous activity that are consistent with the predictions? Much of the evidence from striate cortex suggests that synchronous activity should occur over a time scale of a few (e.g.,  $\pm 5$ ) milliseconds. It is not unreasonable to think, however, that slower time scales of correlated firing, on the order of 10–50 ms, may be the relevant parameter (Vaadia and Aertsen, 1992; Nowak et al., 1995b, 1999). Synchronous activity should develop rapidly after the onset of the stimulus, probably within 50–150 ms, and should certainly be apparent before the onset of a motor response. The duration of synchronous firing is more difficult to predict. It is conceivable that only one or a few synchronous spikes would be sufficient to signal the relations among features, or it may require a more sustained period of correlated activity lasting tens, or perhaps hundreds, of milliseconds. In any case, such brief periods of correlated firing are likely to be difficult to detect and will require analysis methods that are sensitive to such brief correlations (Aertsen et al., 1989; Gray et al., 1992; Vaadia et al., 1995; Riehle et al., 1997).

Second, what constitutes different parts of the same figure? Here, the prediction will vary with the cortical area being investigated. For striate cortex, particularly that of the primate, the spatial scale is likely to be critical. It does not seem reasonable to postulate correlated firing between cells that are separated by great distances and hence are responding to features that are widely separated in the visual field. The most appropriate scale to search for neuronal interactions in primate striate cortex is likely to fall within 5 mm of separation and thus a few degrees of visual angle. The figures will have to be constructed to be consistent with the predicted

spatial scale of the interactions, and this will vary depending on which cortical area is being investigated.

Third, what properties of the stimulus define it as being perceptually segmented? This may be a particularly important point. The visual system is likely to signal figure-ground relationships by using the most efficient mechanism available to it. This means that firing rates across a population of cells may suffice in many instances (e.g., a simple high-contrast object against a uniform background). Given this consideration, it is possible that selective synchronization may come into play in those situations where ambiguities in the stimulus must be resolved (Leonards et al., 1996; Singer, 1999b). Thus, it will be important to use stimuli composed of similar feature elements in which the figure to be detected is defined by one or more of the Gestalt properties relating those elements to one another. Pushed to speculate on this point, I would argue that continuity, closure, and common motion are likely to be the most important.

Supposing that all of the above criteria were met and a result consistent with the predictions was obtained, what other criteria would have to be met for the evidence for the correlation hypothesis to be considered convincing? The answer here is that it should be a robust phenomenon that is present in a significant fraction of the cell population. The difficult question is how robust, and in what percentage? These are qualitative measures that depend on one's own definitions. But these are issues that will have to wait for the results of further experiments.

Finally, what type of negative evidence would favor definitive rejection of the correlation hypothesis as I have stated it? This is more difficult, because negative results from the experiments proposed above probably would not be sufficient to completely reject the hypothesis. One could always resort to the argument that the proposed mechanisms are implemented outside of striate cortex. However, it might be possible to rule out a given cortical area if the results met certain criteria. For example, if there were no detectable differences in the incidence or magnitude of correlated firing across stimulus conditions, this might provide a strong case. I have stated my reasons earlier for why I believe the experiment of Lamme and Spekreijse (1999) does not meet these criteria. Another scenario might be that correlated firing is conspicuously absent or reduced in strength for those stimuli fulfilling the Gestalt grouping criteria. This might indicate that the absence of correlated firing is the relevant signal (see de Oliveria et al., 1997, for a related result). Finally, it might be the case that correlated firing is absent under all of the stimulus conditions for a given experiment. This is likely to be less convincing, because it could be argued that the relevant cell populations were not sampled during the experiment. In the end, if the hypothesis is incorrect, it will require negative evidence from a variety of experiments to kill it. On the other hand, if it is correct, a few key positive results, replicated for rigor, might be sufficient for even the critics to accept it.

## Conclusions

Having reviewed some of the available evidence for, as well as against, the temporal correlation hypothesis, it is appropriate to ask what conclusions can be drawn

with confidence and what questions remain open for future studies. As I see it, these questions fall into four general categories. The first concerns the psychophysical foundations of the theory. As I have outlined here, the correlation hypothesis relies on the notion that perceptual grouping is a rapid, preattentive process that acts in parallel over the visual field to “bind” features with common properties into larger units. Although there is much ongoing debate concerning the details of this process, nearly 80 years of psychophysical research indicate that this fundamental concept is sound.

Given this conclusion, the second category of questions concerns the neurophysiological basis of perceptual grouping. Because of the retinotopic organization of visual cortex and its parallel nature, grouping must involve the integration of information from distributed populations of cells. I have briefly reviewed the evidence for two candidate mechanisms, hierarchical convergence and population coding. The evidence indicates that both mechanisms operate together, but concerns raised by the correlation hypothesis suggest that additional mechanisms must be involved. In its simplest form, convergence coding cannot solve the problem, because the constraints on flexibility, anatomical wiring, and numbers of cells are too severe. Population coding appears to solve these problems, but may itself suffer from a superposition problem that is due to the parallel nature of the grouping process. Some mechanism should be available to distinguish one group of bound features, and hence one population of active neurons, from another. This argument appears valid, but it should be pointed out that it is primarily a theoretical construct. We don't know for certain that a “binding” problem exists that requires a neural solution. If we accept that superposition is a problem, then it appears that some form of assembly-based representation is required. The correlation hypothesis posits that cell assemblies are formed when a common pattern of synchronous firing is established among the participating cells.

This raises a third set of questions. Does existing evidence support this definition of cell assemblies, and if so, do they exhibit the properties required by the theory to account for perceptual grouping? The answer to the first question appears to be yes. There is an abundance of evidence, from visual cortex and many other neural structures, demonstrating the existence and properties of dynamic ensembles of synchronously firing cells. The answer to the second question is more equivocal. The evidence for synchronous activity clearly satisfies some of the requirements of the correlation hypothesis. But the strongest predictions of the theory are also the ones for which the least evidence is available. In spite of this, and in contrast to the viewpoints expressed by some critics of the theory, none of the existing evidence points to an outright rejection of the theory. The resolution of these issues will have to await the results of future experimental studies.

A fourth category of questions concerns the physiological plausibility of the theory. It has been argued that cortical neurons may not possess the requisite biophysical mechanisms to establish synchronous interactions with subsets of their active inputs. I have argued to the contrary that cortical neurons possess an impressive

array of mechanisms to generate and respond to patterns of synchronous activity. It remains to be determined how these mechanisms operate together to select certain inputs for processing. In this context, the anatomical connectivity that provides the substrate for perceptual grouping is critical. The appropriate connections must be available to provide a wide repertoire of possible dynamic assemblies. In his early formulations of the theory, von der Malsburg (1981) proposed the existence of a network of horizontal connections in visual cortex that links populations of neurons with similar receptive field properties. In the years since, much evidence has accumulated to support this prediction (Gilbert and Wiesel, 1983, 1989; Blasdel et al., 1992, *Soc. Neurosci.*, abstract; Malach et al., 1993; Levitt et al., 1996; Yoshioka et al., 1996; Bosking et al., 1997; Kisvarday et al., 1997; Schmidt et al., 1997). When these data are combined with the finding that local (i.e., <500  $\mu\text{m}$  radius) intracortical connections are relatively homogeneous, the anatomical network appears to be well suited for linking activity across a wide array of features (Engel et al., 1990; Das and Gilbert, 1999). These findings suggest the interesting possibility that the Gestalt criteria for perceptual grouping reside in the network of intracortical connections (Roelfsema et al., 1996). If so, this would provide for a large number of possible interactions, with the stimuli and the underlying neuronal dynamics ultimately determining which interactions take place and which features become grouped (Sporns et al., 1991; Roelfsema et al., 1996; Yen and Finkel, 1998; Li, 1999a, 1999b; Yen et al., 1999).

In conclusion, the temporal correlation hypothesis remains an attractive theoretical framework for investigating the neural basis of perceptual grouping. The experiments I have proposed provide one way to test several of the key predictions of this theory, but these studies are still correlative in nature. A true test of the predictions would be one in which a causal link could be established between synchronous activity and perception. Recent experiments in the insect olfactory system demonstrate that tests of this sort can be accomplished in simpler nervous systems (Laurent, 1996; MacLeod and Laurent, 1996; Wehr and Laurent, 1996; Stopfer et al., 1997). A similar experiment would clearly be difficult to achieve in the primate visual system. Any manipulation that might perturb the patterns of synchronous firing would be likely to influence the overall distribution of activity as well. Consequently, a rigorous test of the correlation hypothesis may ultimately have to rely on a combination of theoretical and experimental evidence obtained from a variety of studies.

#### Acknowledgments

This work was supported by the National Eye Institute. I thank Shi-Cheng Yen, Jean-Philippe Lachaux, Rony Azouz, Mike Wehr, Stacia Friedman-Hill, Ken Britten, and Bruno Olshausen for their helpful comments on an earlier version of the manuscript.

#### References

A comprehensive reference list for all reviews can be found on pages 111–125.

## References for Reviews on the Binding Problem

- Abeles, M. (1982a). Role of cortical neuron: integrator or coincidence detector? *Israel J. Med. Sci.* 18, 83–92.
- Abeles, M. (1982b). *Studies of Brain Function, Volume 6, Local Cortical Circuits: An Electrophysiological Study* (Berlin: Springer-Verlag).
- Abeles, M. (1991). *Corticomics: Neural Circuits of Cerebral Cortex* (Cambridge: Cambridge University Press).
- Abeles, M., Prut, Y., Bergman, H., and Vaadia, E. (1994). Synchronization in neuronal transmission and its importance for information processing. *Prog. Brain Res.* 102, 395–404.
- Adam, H. (1998). *Figur-Grund-Abtrennung mit rückgekoppelten Merkmalsfeldern*. PhD Thesis, Department of Physics and Astronomy, Ruhr University, Bochum, Germany.
- Adelson, E.H. (1993). Perceptual organization and the judgment of brightness. *Science* 262, 2042–2044.
- Adelson, E.H. (1999). Lightness perception and lightness illusions. In *The Cognitive Neurosciences*, M.S. Gazzaniga, ed. (Cambridge, MA: MIT Press).
- Adelson, E.H., and Movshon, J.A. (1982). Phenomenal coherence of moving visual patterns. *Nature* 300, 523–525.
- Aertsen, A., Gerstein, G.L., Habib, M.K., and Palm, G. (1989). Dynamics of neuronal firing correlation: modulation of “effective connectivity.” *J. Neurophysiol.* 61, 900–917.
- Aertsen, A., Diesmann, M., and Gewaltig, M.-O. (1996). Propagation of synchronous spiking activity in feedforward neural networks. *J. Physiol. (Paris)* 90, 243–247.
- Aiple, F., and Krüger, J. (1988). Neuronal synchrony in monkey striate cortex: interocular signal flow and dependency on spike rates. *Exp. Brain Res.* 72, 141–149.
- Alais, D., Blake, R., and Lee, S.-H. (1998). Visual features that vary together over time group together over space. *Nat. Neurosci.* 1, 160–164.
- Albright, T.D., and Stoner, G.R. (1995). Visual motion perception. *Proc. Natl. Acad. Sci. USA* 92, 2433–2440.
- Alonso, J.-M., and Martinez, L.M. (1998). Functional connectivity between simple cells and complex cells in cat striate cortex. *Nat. Neurosci.* 1, 395–403.
- Alonso, J.-M., Usrey, W.M., and Reid, R.C. (1996). Precisely correlated firing in cells of the lateral geniculate nucleus. *Nature* 383, 815–819.
- Andersen, R.A. (1995). Encoding of intention and spatial location in the posterior parietal cortex. *Cereb. Cortex* 5, 457–469.
- Andersen, R.A. (1997). Multimodal integration for the representation of space in the posterior parietal cortex. *Philos. Trans. R. Soc. Lond. B Biol. Sci.* 352, 1421–1428.
- Anderson, C.H., and Van Essen, D.C. (1987). Shifter circuits: a computational strategy for dynamic aspects of visual processing. *Proc. Natl. Acad. Sci. USA* 84, 6297–6301.
- Arbib, M. (1964). *Brains, Machines and Mathematics* (New York: McGraw-Hill).
- Arguin, M., Cavanagh, P., and Joannette, Y. (1994). Visual feature integration with an attention deficit. *Brain Cogn.* 24, 44–56.
- Arieli, A., Sterkin, A., Grinvald, A., and Aertsen, A. (1996). Dynamics of ongoing activity: explanation of the large variability in evoked cortical responses. *Science* 273, 1868–1871.
- Ashby, F.G., Prinzmetal, W., Ivry, R., and Maddox, W.T. (1996). A formal theory of feature binding in object perception. *Psychol. Rev.* 103, 165–192.
- Assad, J., and Maunsell, J. (1995). Neuronal correlates of inferred motion in primate posterior parietal cortex. *Nature* 373, 518–521.
- Bair, W. (1999). Spike timing in the mammalian visual system. *Curr Opin. Neurobiol.*, in press.
- Bair, W. and Koch, C. (1995). Precision and reliability of neocortical spike trains in the behaving monkey. In *The Neurobiology of Computation*, B.J. Kluwer, ed. (New York: Academic Publishers).
- Bair, W., and Koch, C. (1996). Temporal precision of spike trains in extrastriate cortex of the behaving monkey. *Neural Comput.* 8, 44–66.
- Bair, W., and O’Keefe, L.P. (1998). The influence of fixational eye movements on the response of neurons in area MT of the macaque. *Vis. Neurosci.* 15, 779–786.
- Bair, W., Koch, C., Newsome, W., and Britten, K. (1994). Power spectrum analysis of bursting cells in area MT in the behaving monkey. *J. Neurosci.* 14, 2870–2892.
- Bair, W., Cavanaugh, J.R., and Movshon, J.A. (1997). Reconstructing stimulus velocity from neuronal responses in area MT. In *Advances in Neural Information Processing Systems*, M.C. Mozer, M.I. Jordan, and T. Petsche, eds. (Cambridge, MA: MIT Press).
- Baldi, P., and Meir, R. (1990). Computing with arrays of coupled oscillators: an application to preattentive texture discrimination. *Neural Comput.* 2, 458–471.
- Ballard, D.H., Hinton, G.E., and Sejnowski, T.J. (1983). Parallel visual computation. *Nature* 306, 21–26.
- Barbas, H. (1988). Anatomic organization of basoventral and medio-dorsal visual recipient prefrontal regions in the rhesus monkey. *J. Comp. Neurol.* 276, 313–342.
- Barbas, H., and Pandya, D.N. (1989). Architecture and intrinsic connections of the prefrontal cortex in the rhesus monkey. *J. Comp. Neurol.* 286, 353–375.
- Barlow, H.B. (1972). Single units and cognition: a neurone doctrine for perceptual psychology. *Perception* 1, 371–394.
- Barlow, H.B. (1981). Critical limiting factors in the design of the eye and visual cortex. *Proc. R. Soc. Lond. B Biol. Sci.* 212, 1–34.
- Barlow, H.B. (1985). The twelfth Bartlett memorial lecture: the role of single neurons in the psychology of perception. *Quart. J. Exp. Psychol.* 37, 121–145.
- Bauer, H.-U., and Pawelzik, K. (1993). Alternating oscillatory and stochastic dynamics in a model for a neuronal assembly. *Physica D69*, 380–393.
- Baylis, G.C., Rolls, E.T., and Leonard, C.M. (1985). Selectivity between faces in the responses of a population of neurons in the cortex in the superior temporal sulcus of the monkey. *Brain Res.* 342, 91–102.
- Baylis, G.C., Rolls, E.T., and Leonard, C.M. (1987). Functional subdivisions of the temporal lobe neocortex. *J. Neurosci.* 7, 330–342.
- Beck, J. (1966). Perceptual grouping produced by changes in orientation and shape. *Science* 154, 538–540.
- Beck, J. (1967). Perceptual grouping produced by line figures. *Percept. Psychophys.* 2, 491–495.
- Behrmann, M., and Tipper, S.P. (1994). Object-based attentional mechanisms: evidence from patients with unilateral neglect. In *Attention and Performance, Volume 15, Conscious and Nonconscious Information Processing*, C. Umiltà and M. Moscovitch, eds. (Cambridge, MA: MIT Press).
- Bergen, J.R., and Adelson, E.H. (1988). Early vision and texture perception. *Nature* 333, 363–364.
- Bergen, J.R., and Julesz, B. (1983). Parallel versus serial processing in rapid pattern discrimination. *Nature* 303, 696–698.
- Best, J., Reuss, S., and Dinse, H.R.O. (1986). Lamina-specific differences of visual latencies following photic stimulation in the cat striate cortex. *Brain Res.* 385, 356–360.
- Biederman, I. (1981). On the semantics of a glance at a scene. In *Perceptual Organization*, M. Kubovy and J. Pomerantz, eds. (Hillsdale, NJ: Lawrence Erlbaum Associates).
- Biederman, I. (1987). Recognition by components: A theory of human image understanding. *Psychol. Rev.* 94, 115–147.
- Biederman, I. and Kalocsai, P. (1997). Neurocomputational bases of object and face recognition. *Philos. Trans. R. Soc. Lond. B Biol. Sci.* 352, 1203–1219.
- Bienenstock, E. (1995). A model of neocortex. *Network* 6, 179–224.

- Bienenstock, E., and von der Malsburg, C. (1987). A neural network for invariant pattern recognition. *Europhys. Lett.* **4**, 121–126.
- Blake, R., and Yang, Y. (1997). Spatial and temporal coherence in perceptual binding. *Proc. Natl. Acad. Sci. USA* **94**, 7115–7119.
- Booth, M., and Rolls, E. (1998). View-invariant representations of familiar objects by neurons in the inferior temporal visual cortex. *Cereb. Cortex* **8**, 510–523.
- Borg-Graham, L., Monier, C., and Fregnac, Y. (1996). Voltage-clamp measurement of visually-evoked conductances with whole-cell patch recordings in primary visual cortex. *J. Physiol. (Paris)* **90**, 185–188.
- Borg-Graham, L.J., Monier, C., and Fregnac, Y. (1998). Visual input evokes transient and strong shunting inhibition in visual cortical neurons. *Nature* **393**, 369–373.
- Borisyuk, R.M., Borisyuk, G.N., and Kazanovich, Y.B. (1998). The synchronization principle in modelling of binding and attention. *Membr. Cell Biol.* **11**, 753–761.
- Bosking, W.H., Zhang, Y., Schofield, B., and Fitzpatrick, D. (1997). Orientation selectivity and the arrangement of horizontal connections in tree shrew striate cortex. *J. Neurosci.* **17**, 2112–2127.
- Boussaoud, D., Ungerleider, L.G., and Desimone, R. (1990). Pathways for motion analysis: cortical connections of the medial superior temporal and fundus of the superior temporal visual area in the macaque. *J. Comp. Neurol.* **296**, 462–495.
- Bouyer, J.J., Montaron, M.F., and Rougeul, A. (1981). Fast frontoparietal rhythms during combined focused attentive behaviour and immobility in cat: cortical and thalamic localizations. *Electroencephalogr. Clin. Neurophysiol.* **51**, 244–252.
- Bradley, D.C., Chang, G.C., and Andersen, R.A. (1998). Encoding of three-dimensional structure-from-motion by primate area MT neurons. *Nature* **392**, 714–717.
- Bragin, A., Jando, G., Nadasdy, Z., Hetke, J., Wise, K., and Buzsaki, G. (1995). Gamma (40–100 Hz) oscillation in the hippocampus of the behaving rat. *J. Neurosci.* **15**, 47–60.
- Braitenberg, V. (1978). Cell assemblies in the cerebral cortex. In *Lecture Notes in Biomathematics, Volume 21, Theoretical Approaches in Complex Systems*, R. Heim and G. Palm, eds. (Berlin: Springer).
- Braitenberg, V., and Schuz, A. (1991). *Anatomy of the Cortex: Statistics and Geometry* (Berlin: Springer).
- Braun, J., and Julesz, B. (1998). Dividing attention at little cost: detection and discrimination tasks. *Percept. Psychophys.* **60**, 1–23.
- Bravo, M., and Blake, R. (1990). Preattentive vision and perceptual groups. *Perception* **19**, 515–522.
- Brecht, M., Singer, W., and Engel, A.K. (1998). Correlation analysis of corticotectal interactions in the cat visual system. *J. Neurophysiol.* **79**, 2394–2407.
- Bressler, S.L., Coppola, R., and Nakamura, R. (1993). Episodic multi-regional cortical coherence at multiple frequencies during visual task performance. *Nature* **366**, 153–156.
- Briand, K.A., and Klein, R.M. (1987). Is Posner's "beam" the same as Triesman's "glue"? On the relation between visual orienting and feature integration theory. *J. Exp. Psychol. Hum. Percept. Perform.* **13**, 228–241.
- Britten, K.H., Shadlen, M.N., Newsome, W.T., and Movshon, J.A. (1992). The analysis of visual motion: a comparison of neuronal and psychophysical performance. *J. Neurosci.* **12**, 4745–4765.
- Britten, K.H., Newsome, W.T., Shadlen, M.N., Celebrini, S., and Movshon, J.A. (1996). A relationship between behavioral choice and the visual responses of neurons in macaque MT. *Vis. Neurosci.* **13**, 87–100.
- Brody, C.D. (1998). Slow covariations in neuronal resting potentials can lead to artefactually fast cross-correlations in their spike trains. *J. Neurophysiol.* **80**, 3345–3351.
- Brody, C.D. (1999a). Disambiguating different covariation types. *Neural Comput.* **11**, 1527–1535.
- Brody, C.D. (1999b). Correlations without synchrony. *Neural Comput.* **11**, 1537–1551.
- Brody, C.D. (1999c). Latency, excitability, and spike timing covariations. *Neural Comput.*, in press.
- Bruce, C., Desimone, R., and Gross, C. (1981). Visual properties of neurons in a polysensory area in the superior temporal sulcus of the macaque. *J. Neurophysiol.* **46**, 369–384.
- Bülthoff, H., and Edelman, S. (1992). Psychophysical support for a two-dimensional view interpolation theory of object recognition. *Proc. Natl. Acad. Sci. USA* **89**, 60–64.
- Bülthoff, H.H., Edelman, S.Y., and Tarr, M.J. (1995). How are three-dimensional objects represented in the brain? *Cereb. Cortex* **3**, 247–260.
- Buračas, G., Zador, A., DeWeese, M., and Albright, T. (1998). Efficient discrimination of temporal patterns by motion-sensitive neurons in primate visual cortex. *Neuron* **20**, 959–969.
- Burr, D. (1979). Acuity for apparent vernier offset. *Vision Res.* **19**, 835–837.
- Bush, P., and Sejnowski, T. (1996). Inhibition synchronizes sparsely connected cortical neurons within and between columns in realistic network models. *J. Comput. Neurosci.* **3**, 91–110.
- Bushnell, M.C., Goldberg, M.E., and Robinson, D.L. (1981). Behavioral enhancement of visual responses in monkey cerebral cortex. I. Modulation in posterior parietal cortex related to selective visual attention. *J. Neurophysiol.* **46**, 755–772.
- Buzsaki, G. (1996). The hippocampo-neocortical dialogue. *Cereb. Cortex* **6**, 81–92.
- Buzsaki, G., and Chrobak, J.J. (1995). Temporal structure in spatially organized neuronal ensembles: a role for interneuronal networks. *Curr. Opin. Neurobiol.* **5**, 504–510.
- Buzsaki, G., Leung, L.S., and Vanderwolf, C.H. (1983). Cellular basis of hippocampal EEG in the behaving rat. *Brain Res.* **6**, 139–171.
- Caminiti, R., Ferraina, S., and Johnson, P.B. (1996). The sources of visual information to the primate frontal lobe: a novel role for the superior parietal lobule. *Cereb. Cortex* **6**, 319–328.
- Carney, T., Paradiso, M., and Freeman, R. (1989). A physiological correlate of the Pulfrich effect in cortical neurons of the cat. *Vision Res.* **29**, 155–165.
- Carney, T., Silverstein, D., and Klein, S. (1995). Vernier acuity during image rotation and translation: visual performance limits. *Vision Res.* **35**, 1951–1964.
- Castelo-Branco, M., Neuenschwander, S., and Singer, W. (1998). Synchronization of visual responses between the cortex, lateral geniculate nucleus, and retina in the anesthetized cat. *J. Neurosci.* **18**, 6395–6410.
- Cave, K.R. (1999). The Feature Gate model of visual selection. *Psychol. Res.*, in press.
- Cave, K.R., and Bichot, N.P. (1999). Visuo-spatial attention: beyond a spotlight model. *Psychonom. Bull. Rev.*, in press.
- Cave, K.R., and Kosslyn, S.M. (1989). Varieties of size-specific visual selection. *J. Exp. Psychol. Gen.* **118**, 148–164.
- Cave, K.R., and Wolfe, J.M. (1990). Modeling the role of parallel processing in visual search. *Cogn. Psychol.* **22**, 225–271.
- Chance, F., Nelson, S., and Abbott, L. (1999). Complex cells as cortically amplified simple cells. *Nat. Neurosci.* **2**, 277–282.
- Chelazzi, L., Miller, E.K., Duncan, J., and Desimone, R.C. (1993). A neural basis for visual search in inferior temporal cortex. *Nature* **363**, 345–347.
- Chelazzi, L., Duncan, J., Miller, E.K., and Desimone, R. (1998). Responses of neurons in inferior temporal cortex during memory-guided visual search. *J. Neurophysiol.* **80**, 2918–2940.
- Cheng, K., Hasegawa, T., Saleem, K.S., and Tanaka, K. (1994). Comparison of neuronal selectivity for stimulus speed, length, and contrast in the prestriate visual cortex areas V4 and MT of the macaque monkey. *J. Neurophysiol.* **71**, 2269–2280.
- Chino, Y., Shansky, M., Jankowski, W., and Banser, F. (1983). Effects of rearing kittens with convergent strabismus on development of receptive-field properties in striate cortex neurons. *J. Neurophysiol.* **50**, 265–286.
- Chino, Y.M., Smith, E.L., Wada, H., Ridder, W.H., Langston, A.L., and Leshner, G.A. (1991). Disruption of binocularly correlated signals alters the postnatal development of spatial properties in cat striate cortical neurons. *J. Neurophysiol.* **65**, 841–859.

- Chrobak, J.J., and Buzsaki, G. (1998). Gamma oscillations in the entorhinal cortex of the freely behaving rat. *J. Neurosci.* 18, 388–398.
- Churchland, P.S., Ramachandran, V.S., and Sejnowski, T.J. (1994). A critique of pure vision. In *Large-Scale Neuronal Theories of the Brain*, C. Koch and J.L. Davis, eds. (Cambridge, MA: MIT Press).
- Cobb, S.R., Buhl, E.H., Halasy, K., Paulsen, O., and Somogyi, P. (1995). Synchronization of neuronal activity in hippocampus by individual GABAergic interneurons. *Nature* 378, 75–78.
- Cohen, A., and Ivry, R.B. (1989). Illusory conjunctions inside and outside the focus of attention. *J. Exp. Psychol. Hum. Percept. Perform.* 15, 650–663.
- Cohen, A., and Ivry, R.B. (1991). Density effects in conjunction search: evidence for coarse location mechanism of feature integration. *J. Exp. Psychol. Hum. Percept. Perform.* 17, 891–901.
- Colby, C.L., and Goldberg, M.E. (1999). Space and attention in parietal cortex. *Annu. Rev. Neurosci.* 22, 319–349.
- Colby, C.L., Duhamel, J.-R., and Goldberg, M.E. (1996). Visual, presaccadic, and cognitive activation of single neurons in monkey lateral intraparietal area. *J. Neurophysiol.* 76, 2841–2852.
- Connor, C.E., Gallant, J.L., Preddie, D.C., and Van Essen, D.C. (1996). Responses in area V4 depend on the spatial relationship between stimulus and attention. *J. Neurophysiol.* 75, 1306–1308.
- Connor, C., Preddie, D., Gallant, J., and van Essen, D. (1997). Spatial attention effects in macaque area V4. *J. Neurosci.* 17, 3201–3214.
- Connors, B.W., and Gutnick, M.J. (1990). Intrinsic firing patterns of diverse neocortical neurons. *Trends Neurosci.* 13, 99–104.
- Connors, B.W., Gutnick, M.J., and Prince, D.A. (1982). Electrophysiological properties of neocortical neurons in vitro. *J. Neurophysiol.* 48, 1302–1320.
- Corbetta, M., Miezin, F.M., Shulman, G.L., and Petersen, S.E. (1993). A PET study of visuospatial attention. *J. Neurosci.* 13, 1202–1226.
- Corbetta, M., Shulman, G.L., Miezin, F.M., and Petersen, S.E. (1995). Superior parietal cortex activation during spatial attention shifts and visual feature conjunction. *Science* 270, 802–805.
- Cowey, A., and Gross, C.G. (1970). Effects of foveal prestriate and inferotemporal lesions on visual discrimination by rhesus monkeys. *Exp. Brain Res.* 11, 128–144.
- Creutzfeldt, O.D., Garey, L.J., Kuroda, R., and Wolff, J.R. (1977). The distribution of degenerating axons after small lesions in the intact and isolated visual cortex of the cat. *Exp. Brain Res.* 27, 419–440.
- Crewther, D., and Crewther, S. (1990). Neural site of strabismic amblyopia in cats: spatial frequency deficit in primary cortical neurons. *Exp. Brain Res.* 79, 615–622.
- Crick, F. (1984). Function of the thalamic reticular complex: the searchlight hypothesis. *Proc. Natl. Acad. Sci. USA* 81, 4586–4590.
- Crick, F., and Koch, C. (1990a). Some reflections on visual awareness. *Cold Spring Harbor Symp. Quant. Biol.* 55, 953–962.
- Crick, F., and Koch, C. (1990b). Towards a neurobiological theory of consciousness. *Sem. Neurosci.* 2, 263–275.
- Damasio, A.R. (1985). Disorders of complex visual processing: agnosia, achromatopsia, Balint's syndrome, and related difficulties of orientation and construction. In *Principles of Behavioral Neurology*, M.M. Mesulam, ed. (Philadelphia: Davis).
- Das, A., and Gilbert, C.D. (1995). Receptive field expansion in adult visual cortex is linked to dynamic changes in strength of cortical connections. *J. Neurophysiol.* 74, 779–792.
- Das, A., and Gilbert, C.D. (1999). Topography of contextual modulations mediated by short-range interactions in primary visual cortex. *Nature* 399, 655–661.
- Dean, P. (1976). Effects of inferotemporal lesions on the behavior of monkeys. *Psychol. Bull.* 83, 41–71.
- DeAngelis, G.C., Ghose, G.M., Ohzawa, I., and Freeman, R.D. (1999). Functional micro-organization of primary visual cortex: receptive field analysis of nearby neurons. *J. Neurosci.* 19, 4046–4064.
- deCharms, R., and Merzenich, M. (1996). Primary cortical representation of sounds by the coordination of action-potential timing. *Nature* 381, 610–613.
- deCharms, R.C., Blake, D.T., and Merzenich, M.M. (1998). Optimizing sound features for cortical neurons. *Science* 280, 1439–1443.
- De Oliveira, S.C., Thiele, A., and Hoffmann, K.P. (1997). Synchronization of neuronal activity during stimulus expectation in a direction discrimination task. *J. Neurosci.* 17, 9248–9260.
- Deppisch, J., Bauer, H.-U., Schillen, T.B., König, P., Pawelzik, K., and Geisel, T. (1993). Alternating oscillatory and stochastic states in a network of spiking neurons. *Network* 4, 243–257.
- Desimone, R. (1991). Face-selective cells in the temporal cortex of monkeys. *J. Cogn. Neurosci.* 3, 1–8.
- Desimone, R., and Duncan, J. (1995). Neural mechanisms of selective visual attention. *Annu. Rev. Neurosci.* 18, 193–222.
- Desimone, R., and Schein, S. (1987). Visual properties of neurons in area V4 of the macaque: sensitivity to stimulus form. *J. Neurophysiol.* 57, 835–868.
- Desimone, R., and Ungerleider, L. (1986). Multiple visual areas in the caudal superior temporal sulcus of the macaque. *J. Comp. Neurol.* 248, 164–189.
- Desimone, R., Albright, T.D., Gross, C.G., and Bruce, C. (1984). Stimulus-selective properties of inferior temporal neurons in the macaque. *J. Neurosci.* 4, 2051–2062.
- Desimone, R., Schein, S.J., Moran, J., and Ungerleider, L.G. (1985). Contour, color and shape analysis beyond the striate cortex. *Vision Res.* 25, 441–452.
- Dev, P. (1975). Perception of depth surfaces in random-dot stereograms: a neural model. *Int. J. Man-Machine Stud.* 7, 511–528.
- DeValois, R.L., and DeValois, K.K. (1988). *Spatial Vision* (New York: Oxford University Press).
- DeValois, R.L., Albrecht, D.G., and Thorell, L.G. (1982a). Spatial frequency selectivity of cells in macaque visual cortex. *Vision Res.* 22, 545–559.
- DeValois, R.L., Yund, E.W., and Hepler, N. (1982b). The orientation and direction selectivity of cells in macaque visual cortex. *Vision Res.* 22, 531–544.
- DeYoe, E.A., and Van Essen, D.C. (1985). Segregation of efferent connections and receptive field properties in visual area V2 of the macaque. *Nature* 317, 58–61.
- DeYoe, E.A., and Van Essen, D.C. (1988). Concurrent processing streams in monkey visual cortex. *Trends Neurosci.* 11, 219–226.
- Diesmann, M., Gewaltig, M.-O., and Aertsen, A. (1997). Cortical synfire activity—a two dimensional state space analysis. In *From Membrane to Mind: Proceedings of the 25th Gottinger Neurobiology Conference*, H. Wässle and N. Elsner, eds. (Stuttgart: Thieme-Verlag).
- Dixon, P., and Shedden, J.M. (1987). Conceptual and physical differences in the category effect. *Percept. Psychophys.* 42, 457–464.
- Dodwell, P.C., and Humphrey, G.K. (1992). A functional theory of the McCollough effect. *Psych. Rev.* 97, 78–89.
- Donnelly, N., Humphreys, G.W., and Riddoch, M.J. (1991). Parallel computation of primitive shape descriptions. *J. Exp. Psychol. Hum. Percept. Perform.* 17, 561–570.
- Donoghue, J.P., Sanes, J.N., Hatsopoulos, N.G., and Gaal, G. (1998). Neural discharge and local field potential oscillations in primate motor cortex during voluntary movement. *J. Neurophysiol.* 79, 159–173.
- Doupe, A.J. (1997). Song- and order-selective neurons in the songbird anterior forebrain and their emergence during vocal development. *J. Neurosci.* 17, 1147–1167.
- Dubner, R., and Zeki, S.M. (1971). Response properties and receptive fields of cells in an anatomically defined region of the superior temporal sulcus. *Brain Res.* 35, 528–532.
- Duncan, J. (1983). Category effects in visual search: a failure to replicate the “oh-zero” phenomenon. *Percept. Psychophys.* 34, 221–232.
- Duncan, J. (1984). Selective attention and the organization of visual information. *J. Exp. Psychol. Gen.* 113, 501–517.
- Eckes, C., and Vorbrüggen, C.V. (1996). Combining data-driven and model-based cues for segmentation of video sequences. In *WCNN 1996* (San Diego: Lawrence Erlbaum).
- Eckhorn, R., Bauer, R., Jordan, W., Brosch, M., Kruse, W., Munk, M., and Reitboeck, H.J. (1988). Coherent oscillations: a mechanism for feature linking in the visual cortex? *Biol. Cybern.* 60, 121–130.

- Eckhorn, R., Frien, A., Bauer, R., Woelbern, T., and Kehr, H. (1993). High frequency 60–90 Hz oscillations in primary visual cortex of awake monkey. *Neuroreport* 4, 243–246.
- Edelman, G.M. (1978). Group selection and phasic reentrant signaling: a theory of higher brain function. In *The Mindful Brain: Cortical Organization and the Group-Selective Theory of Higher Brain Function*. G.M. Edelman and V.B. Mountcastle, eds. (Cambridge, MA: MIT Press).
- Edelman, G.M. (1987). *Neural Darwinism: The Theory of Neuronal Group Selection* (New York: Basic Books).
- Edelman, G.M. (1989). *The Remembered Present: A Biological Theory of Consciousness* (New York: Basic Books).
- Edwards, D.P., Purpura, K.P., and Kaplan, E. (1995). Contrast sensitivity and spatial frequency response of primate cortical neurons in and around the cytochrome oxidase blobs. *Vision Res.* 35, 1501–1523.
- Eggers, H., and Blakemore, C. (1978). Physiological basis of an isometric amblyopia. *Science* 201, 264–267.
- Elder, J., and Zucker, S. (1993). The effect of contour closure on the rapid discrimination of two-dimensional shapes. *Vision Res.* 33, 981–991.
- Engel, A.K., König, P., Gray, C.M., and Singer, W. (1990). Stimulus-dependent neuronal oscillations in cat visual cortex: inter-columnar interaction as determined by cross-correlation analysis. *Eur. J. Neurosci.* 2, 588–606.
- Engel, A.K., König, P., Kreiter, A.K., and Singer, W. (1991a). Inter-hemispheric synchronization of oscillatory neuronal responses in cat visual cortex. *Science* 252, 1177–1179.
- Engel, A.K., Kreiter, A.K., König, P., and Singer, W. (1991b). Synchronization of oscillatory neuronal responses between striate and extrastriate visual cortical areas of the cat. *Proc. Natl. Acad. Sci. USA* 88, 6048–6052.
- Engel, A.K., König, P., and Singer, W. (1991c). Direct physiological evidence for scene segmentation by temporal coding. *Proc. Natl. Acad. Sci. USA* 88, 9136–9140.
- Engel, A.K., König, P., and Singer, W. (1992a). Reply to: The functional nature of neuronal oscillations. *Trends Neurosci.* 15, 387–388.
- Engel, A.K., König, P., Kreiter, A.K., Chillen, T.B., and Singer, W. (1992b). Temporal coding in the visual cortex: new vista on integration in the nervous system. *Trends Neurosci.* 15, 218–225.
- Engel, A.K., Roelfsema, P.R., Fries, P., Brecht, M., and Singer, W. (1997). Role of the temporal domain for response selection and perceptual binding. *Cereb. Cortex* 7, 571–582.
- Eskandar, E.N., and Assad, J.A. (1999). Dissociation of visual motor and predictive signals in parietal cortex during visual guidance. *Nat. Neurosci.* 2, 88–93.
- Fahle, M., and Koch, C. (1995). Spatial displacement, but not temporal asynchrony, destroys figural binding. *Vision Res.* 35, 491–494.
- Fahle, M., and Poggio, T. (1981). Visual hyperacuity: spatio-temporal interpolation in human vision. *Proc. R. Soc. Lond. B Biol. Sci.* 213, 451–477.
- Fang, S.-P., and Wu, P. (1989). Illusory conjunctions in the perception of Chinese characters. *J. Exp. Psychol. Hum. Percept. Perform.* 15, 434–447.
- Felleman, D.J., and Van Essen, D.C. (1987). Receptive field properties of neurons in area V3 of macaque monkey extrastriate cortex. *J. Neurophysiol.* 57, 889–920.
- Felleman, D.J., and van Essen, D.C. (1991). Distributed hierarchical processing in the primate cerebral cortex. *Cereb. Cortex* 1, 1–47.
- Ferrera, V.P., and Lisberger, S.G. (1995). Attention and target selection for smooth pursuit eye movements. *J. Neurosci.* 15, 7472–7484.
- Ferrera, V.P., Rudolph, K.K., and Maunsell, J.H.R. (1994). Responses of neurons in the parietal and temporal visual pathways during a motion task. *J. Neurosci.* 14, 6171–6186.
- Fetz, E., Toyama, K., and Smith, W. (1991). Synaptic interactions between cortical neurons. In *Cerebral Cortex*, A. Peters and E.G. Jones, eds. (New York: Plenum Press).
- Fodor, J.A., and Pylyshyn, Z.W. (1988). Connectionism and cognitive architecture: a critical analysis. *Cognition* 28, 3–71.
- Folk, C.L., and Egeth, H. (1989). Does the identification of simple features require serial processing? *J. Exp. Psychol. Hum. Percept. Perform.* 15, 97–110.
- Foster, K.H., Gaska, J.P., Nagler, M., and Pollen, D.A. (1985). Spatial and temporal frequency selectivity of neurones in visual cortical areas V1 and V2 of the macaque monkey. *J. Physiol. (Lond.)* 365, 331–363.
- Franz, V., Gegenfurtner, K.R., Fahle, M., and Buelthoff, H.H. (1999). Grasping visual illusions: no evidence for a dissociation between perception and action. *Psychol. Sci.*, in press.
- Freeman, W.J. (1975). *Mass Action in the Nervous System* (New York: Academic Press).
- Freeman, W.J., and Skarda, C.A. (1985). Spatial EEG-patterns, nonlinear dynamics and perception: the neo-Sherrington view. *Brain Res. Rev.* 10, 147–175.
- Freiwald, W.A., Kreiter, A.K., and Singer, W. (1995). Stimulus dependent intercolumnar synchronization of single unit responses in cat area 17. *Neuroreport* 6, 2348–2352.
- Friedman-Hill, S.R., Robertson, L.C., and Treisman, A. (1995). Parietal contributions to visual feature binding: evidence from a patient with bilateral lesions. *Science* 269, 853–855.
- Friedman-Hill, S., Maldonado, P.E., and Gray, C.M. (1999). Temporal dynamics of neuronal activity in the striate cortex of alert macaque: I. Incidence and stimulus-dependence of oscillations. *J. Neurosci.*, in press.
- Frien, A., Eckhorn, R., Bauer, R., Woelbern, T., and Kehr, H. (1994). Stimulus-specific fast oscillations at zero phase between visual areas V1 and V2 of awake monkey. *Neuroreport* 5, 2273–2277.
- Fries, P., Roelfsema, P.R., Engel, A.K., König, P., and Singer, W. (1997). Synchronization of oscillatory responses in visual cortex correlates with perception in interocular rivalry. *Proc. Natl. Acad. Sci. USA* 94, 12699–12704.
- Fuji, H., Ito, H., Aihara, K., Ichinose, N., and Tsukada, M. (1996). Dynamical cell assembly hypothesis-theoretical possibility of spatio-temporal coding in the cortex. *Neural Network* 9, 1303–1350.
- Fujita, I., Tanaka, K., Ito, M., and Cheng, K. (1992). Columns for visual features of objects in monkey inferotemporal cortex. *Nature* 360, 343–346.
- Fukushima, K. (1980). Neocognitron: a self-organizing neural network model for a mechanism of pattern recognition unaffected by shift in position. *Biol. Cybern.* 36, 193–202.
- Gallant, J.L., Connor, C.E., Rakshit, S., Lewis, J.W., and Van Essen, D.C. (1996). Neural responses to polar, hyperbolic, and cartesian gratings in area V4 of the macaque monkey. *J. Neurophysiol.* 76, 2718–2739.
- Gattass, R., Sousa, A.P., and Gross, C.G. (1988). Visuotopic organization and extent of V3 and V4 of the macaque. *J. Neurosci.* 8, 1831–1845.
- Gawne, T.J., Kjaer, T.W., and Richmond, B.J. (1996). Latency: another potential code for feature binding in striate cortex. *J. Neurophysiol.* 76, 1356–1360.
- Geesaman, B.J., and Andersen, R.A. (1996). The analysis of complex motion patterns by form/cue invariant MSTd neurons. *J. Neurosci.* 16, 4716–4732.
- Geisler, W.S., and Albrecht, D.G. (1995). Bayesian analysis of identification performance in monkey visual cortex: nonlinear mechanisms and stimulus certainty. *Vision Res.* 35, 2723–2730.
- Georgopoulos, A.P., Ashe, J., Smyrnis, N., and Taira, M. (1992). The motor cortex and the coding of force. *Science* 256, 1692–1695.
- Gerstein, G.L., Bedenbaugh, P., and Aertsen, M.H. (1989). Neuronal assemblies. *IEEE Trans. Biomed. Eng.* 36, 4–14.
- Gerstner, W., and van Hemmen, J.L. (1993). Coherence and incoherence in a globally coupled ensemble of pulse-emitting units. *Phys. Rev. Lett.* 7, 312–315.
- Gerstner, W., Kempter, R., Van Hemmen, J.L., and Wagner, H. (1996). A neuronal learning rule for sub-millisecond temporal coding. *Nature* 383, 76–78.
- Ghose, G.M., and Freeman, R.D. (1992). Oscillatory discharge in the visual system: does it have a functional role? *J. Neurophysiol.* 68, 1558–1574.

- Ghose, G.M., and Freeman, R.D. (1997). Intracortical connections are not required for oscillatory activity in the visual cortex. *Vis. Neurosci.* 14, 963R-979R.
- Ghose, G.M., and Maunsell, J. (1999). Specialized representations in visual cortex: a role for binding? *Neuron* 24, this issue, 79-85.
- Ghose, G.M., and Ts'o, D.Y. (1997). Form processing modules in primate area V4. *J. Neurophysiol.* 77, 2191-2196.
- Gibson, J.R., and Maunsell, J.H.R. (1997). The sensory modality specificity of neural activity related to memory in visual cortex. *J. Neurophysiol.* 78, 1263-1275.
- Gilbert, C.D., and Wiesel, T.N. (1979). Morphology and intracortical projections of functionally characterized neurones in the cat visual cortex. *Nature* 280, 120-125.
- Gilbert, C.D., and Wiesel, T.N. (1983). Clustered intrinsic connections in cat visual cortex. *J. Neurosci.* 3, 1116-1133.
- Gilbert, C.D., and Wiesel, T.N. (1989). Columnar specificity of intrinsic horizontal and cortico-cortical connections in cat visual cortex. *J. Neurosci.* 9, 2432-2442.
- Givre, S.J., Arezzo, J.C., and Schroeder, C.E. (1995). Effects of wavelength on the timing and laminar distribution of illuminance-evoked activity in macaque V1. *Vis. Neurosci.* 12, 229-239.
- Gizzi, M.S., Newsome, W.T., and Movshon, J.A. (1983). Directional selectivity of neurons in macaque MT. *Invest. Ophthalmol. Vis. Sci.* 24 (suppl.), 107.
- Gizzi, M.S., Katz, E., Schumer, R.A., and Movshon, J.A. (1990). Selectivity for orientation and direction of motion of single neurons in cat striate and extrastriate visual cortex. *J. Neurophysiol.* 63, 1529-1543.
- Goldsmith, M. (1998). What's in a location? Comparing object-based and space-based models of feature integration in visual search. *J. Exp. Psychol.* 127, 189-219.
- Goldstone, R.L. (1998). Perceptual learning. *Annu. Rev. Psychol.* 49, 585-612.
- Goodale, M. (1993). Visual pathways supporting perception and action in the primate cerebral cortex. *Curr. Opin. Neurobiol.* 3, 578-585.
- Goodale, M., and Humphrey, G. (1998). The objects of action and perception. *Cognition* 67, 181-207.
- Goodale, M.A., and Milner, A.D. (1992). Separate visual pathways for perception and action. *Trends Neurosci.* 15, 20-25.
- Goodale, M.A., Milner, A.D., Jakobson, L.S., and Carey, D.P. (1991). A neurological dissociation between perceiving objects and grasping them. *Nature* 349, 154-156.
- Goodale, M.A., Meenan, J.P., Bulthoff, H.H., Nicolle, D.A., Murphy, K. J., and Racicot, C.I. (1994). Separate neural pathways for visual analysis of object shape in perception and prehension. *Curr. Biol.* 4, 604-610.
- Goolkasian, P. (1988). Illusory conjunctions in the processing of clock times. *J. Gen. Psychol.* 115, 341-353.
- Gottlieb, J.P., Kusunoki, M., and Goldberg, M.E. (1998). The representation of visual salience in monkey parietal cortex. *Nature* 397, 481-484.
- Graham, N. (1989). *Visual Pattern Analyzers* (New York: Oxford University Press).
- Gray, C.M. (1994). Synchronous oscillations in neuronal systems: mechanisms and functions. *J. Comput. Neurosci.* 7, 11-38.
- Gray, C.M. (1999). The temporal correlation hypothesis of visual feature integration: still alive and well. *Neuron* 24, this issue, 31-47.
- Gray, C.M., and McCormick, D.A. (1996). Chattering cells: superficial pyramidal neurons contributing to the generation of synchronous oscillations in the visual cortex. *Science* 274, 109-113.
- Gray, C.M., and Singer, W. (1989). Stimulus-specific neuronal oscillations in orientation columns of cat visual cortex. *Proc. Natl. Acad. Sci. USA* 86, 1698-1702.
- Gray, C.M., and Viana Di Prisco, G. (1997). Stimulus-dependent neuronal oscillations and local synchronization in striate cortex of the alert cat. *J. Neurosci.* 17, 3239-3253.
- Gray, C.M., Koenig, P., Engel, A.K., and Singer, W. (1989). Oscillatory responses in cat visual cortex exhibit inter-columnar synchronization which reflects global stimulus properties. *Nature* 338, 334-337.
- Gray, C.M., Engel, A.K., Koenig, P., and Singer, W. (1990). Stimulus-dependent neuronal oscillations in cat visual cortex: receptive field properties and feature dependence. *Eur. J. Neurosci.* 2, 607-619.
- Gray, C.M., Engel, A.K., Koenig, P., and Singer, W. (1992). Synchronization of oscillatory neuronal responses in cat striate cortex: temporal properties. *Vis. Neurosci.* 8, 337-347.
- Green, M. (1992). Visual search: detection, identification and localization. *Perception* 21, 765-777.
- Gregory, R.L. (1970). *The Intelligent Eye* (London: Weidenfeld and Nicholson).
- Gross, C.G., Cowey, A., and Manning, F.J. (1971). Further analysis of visual discrimination deficits following foveal prestriate and inferotemporal lesions in rhesus monkeys. *J. Comp. Physiol. Psychol.* 76, 1-7.
- Gross, C.G., Rocha-Miranda, C.E., and Bender, D.B. (1972). Visual properties of neurons in inferotemporal cortex of the macaque. *J. Neurophysiol.* 35, 96-111.
- Grossberg, S. (1995). The attentive brain. *Am. Scientist* 83, 438-449.
- Grossberg, S. (1999a). The link between brain learning, attention, and consciousness. *Conscious. Cogn.*, in press.
- Grossberg, S. (1999b). How does the cerebral cortex work? *Spat. Vis.*, in press.
- Grossberg, S., and Somers, D. (1991). Synchronized oscillations during cooperative feature linking in a cortical model of visual perception. *Neural Networks* 4, 453-466.
- Haenny, P.D., Maunsell, J.H.R., and Schiller, P.H. (1988). State dependent activity in monkey visual cortex. II. Retinal and extraretinal factors in V4. *Exp. Brain Res.* 69, 245-259.
- Hata, Y., Tsumoto, T., Sato, H., and Tamura, H. (1991). Horizontal interactions between visual cortical neurones studied by cross-correlation analysis in the cat. *J. Physiol.* 441, 593-614.
- Hatsopoulos, N.G., Ojakangas, C.L., Paninski, L., and Donoghue, J.P. (1998). Information about movement direction obtained from synchronous activity of motor cortical neurons. *Proc. Natl. Acad. Sci. USA* 95, 15706-15711.
- Hayek, F.A. (1952). *The Sensory Order* (Chicago: University of Chicago Press).
- Hebb, D.O. (1949). *The Organization of Behavior* (New York: Wiley).
- Heeger, D. (1992). Normalization of cell responses in cat striate cortex. *Vis. Neurosci.* 9, 181-197.
- Hellwig, B., Schuz, A., and Aertsen, A. (1994). Synapses on axon collaterals of pyramidal cells are spaced at random intervals: a Golgi study in the mouse cerebral cortex. *Biol. Cybern.* 71, 1-12.
- Herculano-Houzel, S., Munk, M.H., Neuenschwander, S., and Singer, W. (1999). Precisely synchronized oscillatory firing patterns require electroencephalographic activation. *J. Neurosci.* 19, 3992-4010.
- Hess, R., Campbell, F., and Greenhalgh, T. (1978). On the nature of the neural abnormality in human amblyopia: neural aberrations and neural sensitivity loss. *Pflügers Arch.* 377, 201-207.
- Hinton, G.E.A. (1981). A parallel computation that assigns canonical object-based frames of reference. In *Proceedings of the Seventh International Joint Conference on Artificial Intelligence, Volume 2* (Vancouver).
- Hoffman, J.E. (1979). A two-stage model of visual search. *Percept. Psychophys.* 25, 319-327.
- Hoffman, D.A., Magee, J.C., Colbert, C.M., and Johnston, D. (1997). K<sup>+</sup> channel regulation of signal propagation in dendrites of hippocampal pyramidal neurons. *Nature* 387, 869-875.
- Hommel, B. (1998). Event files: evidence for automatic integration of stimulus-response episodes. *Vis. Cogn.* 5, 183-216.
- Hopfield, J.J., and Hertz, A.V.M. (1995). Rapid local synchronization of action potentials: toward computation with coupled integrate-and-fire neurons. *Proc. Natl. Acad. Sci. USA* 92, 6655-6662.
- Hoppensteadt, F.C., and Izhikevich, E.M. (1998). Thalamo-cortical interactions modeled by weakly connected oscillators: could the brain use FM radio principles? *Biosystems* 48, 85-94.
- Horwitz, G.D., and Newsome, W.T. (1999). Separate signals for target selection and movement specification in the superior colliculus. *Science* 284, 1158-1161.

- Houck, M.R., and Hoffman, J.E. (1986). Conjunction of color and form without attention. Evidence from an orientation-contingent color aftereffect. *J. Exp. Psychol. Hum. Percept. Perform.* *12*, 186–199.
- Howard, I.P., and Rogers, B.J. (1995). *Binocular Vision and Stereopsis* (Oxford: Oxford University Press).
- Hubel, D., and Wiesel, T. (1962). Receptive fields, binocular interaction and functional architecture in the cat's visual cortex. *J. Physiol.* *160*, 106–154.
- Hubel, D., and Wiesel, T. (1965). Receptive fields and functional architecture in two nonstriate visual areas (18 and 19) of the cat. *J. Neurophysiol.* *28*, 229–289.
- Hubel, D.H., and Wiesel, T.N. (1968). Receptive fields and functional architecture of monkey striate cortex. *J. Physiol. (Lond.)* *195*, 215–243.
- Hubel, D.H., and Wiesel, T.N. (1974). Sequence regularity and geometry or orientation columns in the monkey striate cortex. *J. Comp. Neurol.* *158*, 267–294.
- Huerta, P.T., and Lisman, J.E. (1996). Low-frequency stimulation at the throughs of Q-oscillation induces long-term depression of previously potentiated CA1 synapses. *J. Neurophysiol.* *75*, 877–884.
- Hummel, J.E., and Biederman, I. (1992). Dynamic binding in a neural network for shape recognition. *Psychol. Rev.* *99*, 480–517.
- Hummel, J.E., and Stankiewicz, B.J. (1996). An architecture for rapid, hierarchical structural description. In *Attention and Performance*, Volume XVI, T. Inui and J. McClelland, eds. (Cambridge, MA: MIT Press).
- Intraub, H. (1981). Identification and naming of briefly glimpsed visual scenes. In *Eye Movement: Cognition and Visual Perception*, D.F. Fisher, R.A. Monty, and J.W. Senders, eds. (Hillsdale, NJ: Lawrence Erlbaum Associates).
- Intraub, H. (1985). Visual dissociation: an illusory conjunction of pictures and forms. *J. Exp. Psychol. Hum. Percept. Perform.* *11*, 431–442.
- Ito, M., and Gilbert, C.D. (1999). Attention modulates contextual influences in the primary visual cortex of alert monkeys. *Neuron* *22*, 593–604.
- Ivry, R.B., and Prinzmetal, W. (1991). Effect of feature similarity on illusory conjunctions. *Percept. Psychophys.* *49*, 105–116.
- Jensen, O., and Lisman, J.E. (1998). An oscillatory short-term memory buffer model can account for data on the Sternberg task. *J. Neurosci.* *18*, 10688–10699.
- Johnston, D., Magee, J.C., Colbert, C.M., and Christie, B.R. (1996). Active properties of neuronal dendrites. *Annu. Rev. Neurosci.* *19*, 165–186.
- Jones, J., and Palmer, L. (1987). An evaluation of the two-dimensional Gabor filter model of simple receptive fields in cat striate cortex. *J. Neurophysiol.* *58*, 1233–1258.
- Jonides, J., and Gleitman, H. (1972). A conceptual category effect in visual search: O as letter or digit. *Percept. Psychophys.* *12*, 457–460.
- Julesz, B. (1975). Experiments in the visual perception of texture. *Sci. Am.* *232*, 34–43.
- Kahneman, D. (1973). *Attention and Effort* (Englewood Cliffs, NJ: Prentice-Hall).
- Kahneman, D., and Henik, A. (1981). Perceptual organization and attention. In *Perceptual Organization*, M. Kubovy and J. Pomerantz, eds. (Hillsdale, NJ: Lawrence Erlbaum Associates).
- Kahneman, D., Treisman, A., and Gibbs, B. (1992). The reviewing of object files: object-specific integration of information. *Cogn. Psychol.* *24*, 175–219.
- Kammen, D.M., Holmes, P.J., and Koch, C. (1989). Origin of oscillations in visual cortex: feedback versus local coupling. In *Models of Brain Functions*, R.M.J. Cotterill, ed. (Cambridge: Cambridge University Press).
- Kanisza, G. (1979). *The Organization of Vision* (New York: Praeger).
- Kapadia, M.K., Ito, M., Gilbert, C.D., and Westheimer, G. (1995). Improvement in visual sensitivity by changes in local context: parallel studies in human observers and in V1 of alert monkeys. *Neuron* *15*, 843–856.
- Kastner, S., De Weerd, P., Desimone, R., and Ungerleider, L.G. (1998). Mechanisms of directed attention in the human extrastriate cortex as revealed by functional MRI. *Science* *282*, 108–111.
- Kastner, S., Pinsk, M.A., De Weerd, P., Desimone, R., and Ungerleider, L.G. (1999). Increased activity in human visual cortex during directed attention in the absence of visual stimulation. *Neuron* *22*, 751–761.
- Kefalea, E. (1998). Object localization and recognition for a grasping robot. In *Proceedings of the 24th Annual Conference of the IEEE Industrial Electronics Society* (Aachen, Germany).
- Keil, K., Müller, M.M., Ray, W.J., Gruber, T., and Elbert, T. (1999). Human gamma band activity and perception of a Gestalt. *J. Neurosci.* *19*, 7152–7161.
- Kersten, D. (1999). High-level vision as statistical inference. In *The Cognitive Neurosciences*, M.S. Gazzaniga, ed. (Cambridge, MA: MIT Press).
- Kilgard, M.P., and Merzenich, M.M. (1998). Plasticity of temporal information processing in the primary auditory cortex. *Nat. Neurosci.* *1*, 727–731.
- Kim, J.-N., and Shadlen, M.N. (1999). Neural correlates of a decision in the dorsolateral prefrontal cortex of the macaque. *Nat. Neurosci.* *2*, 176–185.
- Kiorpes, L., and McKee, S.P. (1999). Amblyopia and its neural basis. *Curr. Opin. Neurobiol.*, in press.
- Kiorpes, L., and Movshon, J.A. (1996). Amblyopia: a developmental disorder of the central visual pathways. *Cold Spring Harbor Symp. Quant. Biol.* *61*, 39–48.
- Kiorpes, L., Kiper, D., O'Keefe, L., Cavanaugh, J., and Movshon, J. (1998). Neuronal correlates of amblyopia in the visual cortex of macaque monkeys with experimental strabismus and anisometropia. *J. Neurosci.* *18*, 6411–6424.
- Kiper, D.C., Gegenfurtner, K.R., and Movshon, J.A. (1996). Cortical oscillatory responses do not affect visual segmentation. *Vision Res.* *36*, 539–544.
- Kisvarday, Z.F., Toth, E., Rausch, M., and Eysel, U.T. (1997). Orientation-specific relationship between populations of excitatory and inhibitory lateral connections in the visual cortex of the cat. *Cereb. Cortex* *7*, 605–618.
- Kobatake, E., and Tanaka, K. (1994). Neuronal selectivities to complex object features in the ventral visual pathway of the macaque cerebral cortex. *J. Neurophys.* *71*, 856–857.
- Kobatake, E., Wang, G., and Tanaka, K. (1998). Effects of shape-discrimination training on the selectivity of inferotemporal cells in adult monkeys. *J. Neurophysiol.* *80*, 324–330.
- Koch, C. (1999). *Biophysics of Computation* (New York: Oxford University Press).
- Koch, C., and Poggio, T. (1999). Predicting the visual world: silence is golden. *Nat. Neurosci.* *2*, 9–10.
- Koch, C., and Ullman, S. (1985). Shifts in selective visual attention: towards the underlying neural circuitry. *Hum. Neurobiol.* *4*, 219–227.
- Koch, C., Rapp, M., and Segev, I. (1996). A brief history of time (constants). *Cereb. Cortex* *6*, 93–101.
- Koffka, K. (1935). *Principles of Gestalt Psychology* (New York: Harcourt, Brace and World).
- Koffka, K. (1969). *The Task of Gestalt Psychology* (Princeton: Princeton University Press).
- Köhler, W. (1930). *Gestalt Psychology* (London: Bell and Sons).
- Köhler, W., and Held, R. (1949). The cortical correlate of pattern vision. *Science* *110*, 414–419.
- Konen, W., and von der Malsburg, C. (1993). Learning to generalize from single examples in the dynamic link architecture. *Neural Comput.* *5*, 719–735.
- Konen, W., Maurer, T., and von der Malsburg, C. (1994). A fast dynamic link matching algorithm for invariant pattern recognition. *Neural Networks* *7*, 1019–1030.
- König, P., and Schillen, T.B. (1991). Stimulus-dependent assembly formation of oscillatory responses: I. Synchronization. *Neural Comput.* *3*, 155–166.
- König, P., Engel, A.K., and Singer, W. (1996). Integrator or coincidence detector? The role of the cortical neuron revisited. *Trends Neurosci.* *19*, 130–137.

- König, P., Engel, A.K., and Singer, W. (1995). Relation between oscillatory activity and long-range synchronization in cat visual cortex. *Proc. Natl. Acad. Sci. USA* *92*, 290–294.
- König, P., Engel, A.K., Löwel, S., and Singer, W. (1993). Squint affects synchronization of oscillatory responses in cat visual cortex. *Eur. J. Neurosci.* *5*, 501–508.
- Kovacs, I., and Julesz, B. (1993). A closed curve is much more than an incomplete one: effect of closure in figure-ground segmentation. *Proc. Natl. Acad. Sci. USA* *90*, 7495–7497.
- Kreiter, A.K., and Singer, W. (1992). Oscillatory neuronal responses in the visual cortex of the awake macaque monkey. *Eur. J. Neurosci.* *4*, 369–375.
- Kreiter, A.K., and Singer, W. (1996). Stimulus-dependent synchronization of neuronal responses in the visual cortex of the awake macaque monkey. *J. Neurosci.* *16*, 2381–2396.
- Krüger, L.E. (1984). The category effect in visual search depends on physical rather than conceptual differences. *Percept. Psychophys.* *35*, 558–564.
- Krüger, J., and Aiple, F. (1988). Multimicroelectrode investigation of monkey striate cortex: spike train correlations in the infragranular layers. *J. Neurophysiol.* *60*, 798–828.
- Kwak, H., Dagenbach, D., and Egeth, H. (1991). Further evidence for a time-independent shift of the focus of attention. *Percept. Psychophys.* *49*, 473–480.
- Lades, M., Vorbrüggen, J.C., Buhmann, J., Lange, J., von der Malsburg, C., Würtz, R., and Konen, W. (1993). Distortion invariant object recognition in the dynamic link architecture. *IEEE Trans. Comput.* *42*, 300–311.
- Lamme, V.A. (1995). The neurophysiology of figure-ground segregation in primary visual cortex. *J. Neurosci.* *15*, 1605–1615.
- Lamme, V.A.F., and Spekreijse, H. (1999). Neuronal synchrony does not represent texture segregation. *Nature* *396*, 362–366.
- Lampl, I., Reichova, I., and Ferster, D. (1999). Synchronous membrane potential fluctuations in neurons of the cat visual cortex. *Neuron* *22*, 361–374.
- Larkum, M.E., Zhu, J.J., and Sakmann, B. (1999). A new cellular mechanism for coupling inputs arriving at different cortical layers. *Nature* *398*, 338–341.
- Lashley, K.S., Chow, K.L., and Semmes, J. (1951). An examination of the electrical field theory of cerebral integration. *Psychol. Rev.* *58*, 128–136.
- Laufer, M., and Verzeano, M. (1967). Periodic activity in the visual system of the cat. *Vision Res.* *7*, 215–229.
- Laurent, G. (1996). Dynamical representation of odors by oscillating and evolving neural assemblies. *Trends Neurosci.* *19*, 489–496.
- Laurent, G., Wehr, M., and Davidowitz, H. (1996). Temporal representations of odors in an olfactory network. *J. Neurosci.* *16*, 3837–3847.
- Lavie, N., and Driver, J. (1996). On the spatial extent of attention in object-based visual selection. *Percept. Psychophys.* *58*, 1238–1251.
- Lee, S.-H., and Blake, R. (1999). Visual form created solely from temporal structure. *Science* *284*, 1165–1168.
- Lee, C., Rohrer, W.H., and Sparks, D.L. (1988). Population coding of saccadic eye movements by neurons in the superior colliculus. *Nature* *332*, 357–360.
- Lee, D., Itti, L., Koch, C., and Braun, J. (1999). Attention activates winner-take-all competition among visual filters. *Nat. Neurosci.* *2*, 375–381.
- Legendy, C. (1970). The brain and its information trapping device. In *Progress in Cybernetics*, Volume 1, J. Rose, ed. (New York: Gordon and Breach).
- Lennie, P. (1981). The physiological basis of variations in visual latency. *Vision Res.* *21*, 815–824.
- Lennie, P., Krauskopf, J., and Sclar, G. (1990). Chromatic mechanisms in striate cortex of macaque. *J. Neurosci.* *10*, 649–669.
- Leon, M.I., and Shadlen, M.N. (1998). Exploring the neurophysiology of decisions. *Neuron* *21*, 669–672.
- Leonards, U., Singer, W., and Fahle, M. (1996). The influence of temporal phase differences on texture segmentation. *Vision Res.* *36*, 2689–2697.
- Leonards, U., and Singer, W. (1998). Two segmentation mechanisms with differential sensitivity for colour and luminance contrast. *Vision Res.* *38*, 101–109.
- Leonards, U., Singer, W., and Fahle, M. (1996). The influence of temporal phase differences on texture segmentation. *Vision Res.* *36*, 2689–2697.
- Leopold, D.A., and Logothetis, N.K. (1996). Activity changes in early visual cortex reflect monkeys' percepts during binocular rivalry. *Nature* *379*, 549–553.
- Leventhal, A.G., Thompson, K.G., Liu, D., Zhou, Y., and Ault, S.J. (1995). Concomitant sensitivity to orientation, direction, and color of cells in Layers 2, 3, and 4 of monkey striate cortex. *J. Neurosci.* *15*, 1808–1818.
- Levi, D., and Sharma, V. (1998). Integration of local orientation in strabismic amblyopia. *Vision Res.* *38*, 775–781.
- Levick, W.R., and Zacks, J.L. (1970). Responses of cat retinal ganglion cells to brief flashes of light. *J. Physiol. (Lond.)* *206*, 677–700.
- Levitt, J.B., and Lund, J.S. (1997). Contrast dependence of contextual effects in primate visual cortex. *Nature* *387*, 73–76.
- Levitt, J.B., Kiper, D.C., and Movshon, J.A. (1994). Receptive field and functional architecture of macaque V2. *J. Neurophysiol.* *71*, 2517–2542.
- Levitt, J.B., Lund, J.S., and Yoshioka, T. (1996). Anatomical substrates for early stages in cortical processing of visual information in the macaque monkey. *Behav. Brain Res.* *76*, 5–19.
- Li, C.-Y., and Li, W. (1994). Extensive integration field beyond the classical receptive field of cat striate cortical neurons-classification and tuning properties. *Vision Res.* *34*, 2337–2355.
- Li, Z. (1999a). Visual segmentation by contextual influences via intracortical interactions in the primary visual cortex. *Network Comput. Neural Syst.* *10*, 187–212.
- Li, Z. (1999b). A neural model of contour integration in the primary visual cortex. *Neural Comput.*, in press.
- Lisberger, S.G., and Movshon, J.A. (1999). Visual motion analysis for pursuit eye movements in area MT of macaque monkeys. *J. Neurosci.* *19*, 2224–2246.
- Lisman, J.E. (1997). Bursts as a unit of neural information: making unreliable synapses reliable. *Trends Neurosci.* *20*, 38–43.
- Lisman, J.E., and Idiart, M.A. (1995). Storage of  $7 \pm 2$  short-term memories in oscillatory subcycles. *Science* *267*, 1512–1515.
- Livingstone, M.S. (1996). Oscillatory firing and interneuronal correlations in squirrel monkey striate cortex. *J. Neurophysiol.* *75*, 2467–2485.
- Livingstone, M.S., and Hubel, D.H. (1983). Specificity of cortico-cortical connections in monkey visual system. *Nature* *304*, 531–534.
- Livingstone, M.S., and Hubel, D.H. (1984). Anatomy and physiology of a color system in the primate visual cortex. *J. Neurosci.* *4*, 309–356.
- Livingstone, M.S., and Hubel, D.H. (1988). Segregation of form, color, movement, and depth: anatomy, physiology, and perception. *Science* *240*, 740–749.
- Llinas, R.R. (1988). The intrinsic electrophysiological properties of mammalian neurons: insights into central nervous system function. *Science* *242*, 1654–1664.
- Llinas, R., and Ribary, U. (1993). Coherent 40 Hz oscillation characterizes dream state in humans. *Proc. Natl. Acad. Sci. USA* *90*, 2078–2081.
- Llinas, R.R., Grace, A.A., and Yarom, Y. (1991). In vitro neurons in mammalian cortical layer 4 exhibit intrinsic oscillatory activity in the 10- to 50-Hz frequency range. *Proc. Natl. Acad. Sci. USA* *88*, 897–901.
- Löwel, S., and Singer, W. (1992). Selection of intrinsic horizontal connections in the visual cortex by correlated neuronal activity. *Science* *255*, 209–212.
- Logothetis, N.K. (1998). Single units and conscious vision. *Philos. Trans. R. Soc. Lond. B Biol. Sci.* *353*, 1801–1818.
- Logothetis, N.K., and Pauls, J. (1995). Psychophysical and physiological evidence for viewer-centered object representations in the primate. *Cereb. Cortex* *5*, 270–288.

- Logothetis, N.K., and Schall, J.D. (1989a). Neuronal activity related to motion perception in the middle temporal (MT) visual area of the macaque. In *Neural Mechanisms of Visual Perception: Proceedings of the Retina Research Foundation*, D.M.-K. Lam and C.D. Gilbert, eds. (The Woodlands, TX: Portfolio Publishing Company).
- Logothetis, N.K., and Schall, J.D. (1989b). Neuronal correlates of subjective visual perception. *Science* 245, 761–763.
- Logothetis, N.K., Pauls, J., and Poggio, T. (1995). Shape representation in the inferior temporal cortex of monkeys. *Curr. Biol.* 5, 552–563.
- Luck, S.J., and Vogel, E.K. (1997). The capacity of visual working memory for features and conjunctions. *Nature* 390, 279–281.
- Luck, S.J., Chelazzi, L., Hillyard, S.A., and Desimone, R. (1997a). Neural mechanisms of spatial selective attention in areas V1, V2, and V4 of macaque visual cortex. *J. Neurophysiol.* 77, 24–42.
- Luck, S.J., Girelli, M., McDermott, M.T., and Ford, M.A. (1997b). Bridging the gap between monkey neurophysiology and human perception: an ambiguity resolution theory of visual selective attention. *Cogn. Psychol.* 33, 64–87.
- Lumer, E.D., Edelman, G.M., and Tononi, G. (1997a). Neural dynamic in a model of the thalamocortical system. I. Layers, loops and the emergence of fast synchronous rhythms. *Cereb. Cortex* 7, 207–227.
- Lumer, E.D., Edelman, G.M., and Tononi, G. (1997b). Neural dynamics in a model of the thalamocortical system. II. The role of neural synchrony tested through perturbations of spike timing. *Cereb. Cortex* 7, 228–236.
- Luthi, A., and McCormick, D.A. (1998). H-current: properties of a neuronal and network pacemaker. *Neuron* 21, 9–12.
- Lytton, W.W., and Sejnowski, T.J. (1991). Simulations of cortical pyramidal neurons synchronized by inhibitory interneurons. *J. Neurophysiol.* 66, 1059–1079.
- MacLeod, K., and Laurent, G. (1996). Distinct mechanisms for synchronization and temporal patterning of odor-encoding neural assemblies. *Science* 274, 976–979.
- MacLeod, K., Backer, A., and Laurent, G. (1998). Who reads temporal information contained across synchronized and oscillatory spike trains? *Nature* 395, 693–698.
- Madler, C., and Poppel, E. (1987). Auditory evoked potentials indicate the loss of neuronal oscillations during general anesthesia. *Naturwissenschaften* 74, 42–43.
- Magee, J.C., and Johnstone, D.A. (1997). A synaptically controlled, associative signal for Hebbian plasticity in hippocampal neurons. *Science* 275, 209–213.
- Mainen, Z.F., and Sejnowski, T.J. (1995). Reliability of spike timing in neocortical neurons. *Science* 268, 1503–1506.
- Malach, R., Amir, Y., Harel, M., and Grinvald, A. (1993). Relationship between intrinsic connections and functional architecture revealed by optical imaging and in vivo targeted biocytin injections in primate striate cortex. *Proc. Natl. Acad. Sci. USA* 90, 10469–10473.
- Maldonado, P.E., Friedman-Hill, S.R., and Gray, C.M. (1999). Temporal dynamics of neuronal activity in the striate cortex of alert macaque: II. Short and long-range temporally-correlated activity. *J. Neurosci.*, in press.
- Marcelja, S. (1980). Mathematical description of the responses of simple cortical cells. *J. Optic. Soc. Am.* 70, 1297–1300.
- Margulis, M., and Tang, C.-M. (1998). Temporal integration can readily switch between sublinear and supralinear summation. *J. Neurophysiol.* 79, 2809–2813.
- Markram, H., Lübke, J., Frotscher, M., and Sakmann, B. (1997). Regulation of synaptic efficacy by coincidence of postsynaptic APs and EPSPs. *Science* 275, 213–215.
- Marr, D. (1982). *Vision* (San Francisco: Freeman).
- Marsalek, P., Koch, C., and Maunsell, J.H.R. (1997). On the relationship between synaptic input and spike output jitter in individual neurons. *Proc. Natl. Acad. Sci. USA* 94, 735–740.
- Mason, A., Nicoll, A., and Stratford, K. (1991). Synaptic transmission between individual pyramidal neurons of the rat visual cortex in vitro. *J. Neurosci.* 11, 72–84.
- Massad, A., Mertsching, B., and Schmalz, S. (1998). Combining multiple views and temporal associations for 3-D object recognition. In *Proceedings of the ECCV 1998, Volume 2 Stockholm*.
- Matsumura, M., Chen, D.-F., Sawaguchi, T., Kubota, K., and Fetz, E.E. (1996). Synaptic interactions between primate precentral cortex neurons revealed by spike-triggered averaging of intracellular membrane potentials in vivo. *J. Neurosci.* 16, 7757–7767.
- Maunsell, J.H.R., and Gibson, J.R. (1992). Visual response latencies in striate cortex of the macaque monkey. *J. Neurophysiol.* 68, 1332–1344.
- Maunsell, J.H.R., and Newsome, W.T. (1987). Visual processing in monkey extrastriate cortex. *Annu. Rev. Neurosci.* 10, 363–401.
- Maunsell, J.H., Sclar, G., Nealey, T.A., and DePriest, D.D. (1991). Extraretinal representations in area V4 in the macaque monkey. *Vis. Neurosci.* 7, 561–573.
- Maunsell, J.H.R., Ghose, G.M., Assad, J.A., McAdams, C.J., Boudreau, C.E., and Noerager, B.D. (1999). Visual response latencies of magnocellular and parvocellular LGN neurons in macaque monkeys. *Vis. Neurosci.* 16, 1–14.
- McAdams, C.J., and Maunsell, J.H.R. (1999). Effects of attention on orientation-tuning functions of single neurons in macaque cortical area V4. *J. Neurosci.* 19, 431–441.
- McClelland, J.L., and Mozer, M.C. (1986). Perceptual interactions in two-word displays: familiarity and similarity effects. *J. Exp. Psychol. Hum. Percept. Perform.* 12, 18–35.
- McCullough, C. (1965). Color adaptation of edge-detectors in the human visual system. *Science* 149, 1115–1116.
- McCulloch, W., and Pitts, W. (1943). A logical calculus of the ideas immanent in nervous activity. *Bull. Math. Biophys.* 5, 115–133.
- McCormick, D.A., Connors, B.W., Lighthall, J.W., and Prince, D.A. (1985). Comparative electrophysiology of pyramidal and sparsely spiny stellate neurons of the neocortex. *J. Neurophysiol.* 54, 782–806.
- McLeod, P., Driver, J., and Crisp, J. (1988). Visual search for conjunctions of movement and form is parallel. *Nature* 332, 154–155.
- McLeod, P., Driver, J., Dienes, Z., and Crisp, J. (1991). Filtering by movement in visual search. *J. Exp. Psychol. Hum. Percept. Perform.* 17, 55–64.
- Mel, B., and Fiser, J. (1999). Minimizing binding errors using learned conjunctive features. *Neural Comput.*, in press.
- Melssen, W.J., and Epping, W.J.M. (1987). Detection and estimation of neural connectivity based on cross correlation analysis. *Biol. Cybern.* 57, 403–414.
- Merigan, W.H., and Maunsell, J.H. (1993). How parallel are the primate visual pathways? *Annu. Rev. Neurosci.* 16, 369–402.
- Michalski, A., Gerstein, G.L., Czarkowska, J., and Tarnecki, R. (1983). Interactions between cat striate cortex neurons. *Exp. Brain Res.* 51, 97–107.
- Mikami, A., Newsome, W.T., and Wurtz, R.H. (1986). Motion selectivity in macaque visual cortex. I. Mechanisms of direction and speed selectivity in extrastriate area MT. *J. Neurophysiol.* 55, 1308–1327.
- Miles, R., and Wong, R.K.S. (1986). *J. Physiol.* 380, 373–397.
- Miller, E.C., Gochin, P.M., and Gross, C.G. (1993). Suppression of visual responses of neurons in inferior temporal cortex of the awake macaque monkey by addition of a second stimulus. *Brain Res.* 616, 25–29.
- Milner, P. (1974). A model for visual shape recognition. *Psychol. Rev.* 81, 521–535.
- Milner, A.D., and Goodale, M.A. (1993). Visual pathways to perception and action. *Prog. Brain Res.* 95, 317–337.
- Miltner, W.H.R., Braun, C., Arnold, M., Witte, H., and Taub, E. (1999). Coherence of gamma-band EEG activity as a basis for associative learning. *Nature* 397, 434–436.
- Minsky, M. (1961). Steps toward artificial intelligence. *Proc. Inst. Radio Engr.* 49, 8–30.
- Missal, M., Vogels, R., and Orban, G. (1997). Responses of macaque inferior temporal neurons to overlapping shapes. *Cereb. Cortex* 7, 758–767.
- Moore, G.P., Segundo, J.P., Perkel, D.H., and Levitan, H. (1970). Statistical signs of synaptic interactions in neurones. *Biophys. J.* 10, 876–900.
- Moran, J., and Desimone, R. (1985). Selective attention gates visual processing in the extrastriate cortex. *Science* 229, 782–784.

- Motter, B.C. (1993). Focal attention produces spatially selective processing in visual cortical areas V1, V2, and V4 in the presence of competing stimuli. *J. Neurophysiol.* *70*, 909–919.
- Motter, B.C., and Mountcastle, V.B. (1981). The functional properties of the light-sensitive neurons of the posterior parietal cortex studied in waking monkeys: foveal sparing and opponent vector organization. *J. Neurosci.* *1*, 3–26.
- Mountcastle, V.B. (1978). An organizing principle for cerebral function: the unit module and the distributed system. In *The Mindful Brain*, G.M. Edelman and V.B. Mountcastle, eds. (Cambridge, MA: MIT Press).
- Movshon, J.A., Adelson, E.H., Gizzi, M.S., and Newsome, W.T. (1985). The analysis of moving visual patterns. *Exp. Brain Res.* *71*, 117–151.
- Movshon, J., Eggers, H., Gizzi, M., Hendrickson, A., Kiorpes, L., and Boothe, R. (1987). Effects of early unilateral blur on the macaque's visual system. III. Physiological observations. *J. Neurosci.* *7*, 1340–1351.
- Mozer, M.C. (1983). Letter migration in word perception. *J. Exp. Psychol. Hum. Percept. Perform.* *9*, 531–546.
- Mozer, M. (1991). *The Perception of Multiple Objects: A Connectionist Approach* (Cambridge, MA: MIT Press).
- Munk, M.H.J., Roelfsema, P.R., König, P., Engel, A.K., and Singer, W. (1996). Role of reticular activation in the modulation of intracortical synchronization. *Science* *272*, 271–274.
- Murata, A., Gallese, V., Kaseda, M., and Sakata, H. (1996). Parietal neurons related to memory-guided hand manipulation. *J. Neurophysiol.* *75*, 2180–2186.
- Murthy, V.N., and Fetz, E.E. (1996a). Oscillatory activity in sensorimotor cortex of awake monkeys: synchronization of local field potentials and relation to behavior. *J. Neurophysiol.* *76*, 3949–3967.
- Murthy, V.N., and Fetz, E.E. (1996b). Synchronization of neurons during local field potential oscillations in sensorimotor cortex of awake monkeys. *J. Neurophysiol.* *76*, 3968–3982.
- Nakayama, K., and Silverman, G.H. (1986a). Serial and parallel processing of visual feature conjunctions. *Nature* *320*, 264–265.
- Navon, D. (1975). Forest before trees: the precedence of global features in visual perception. *Cogn. Psychol.* *9*, 353–383.
- Neisser, U. (1963). Decision-time without reaction-time: experiments in visual scanning. *Am. J. Psychol.* *76*, 376–385.
- Neisser, U. (1967). *Cognitive Psychology* (New York: Appleton-Century-Crofts).
- Neisser, U., and Becklen, R. (1975). Selective looking: attending to visually specified events. *Cogn. Psychol.* *7*, 480–494.
- Nelson, J.I., Salin, P.A., Munk, M.H.J., Arzi, M., and Bullier, J. (1992). Spatial and temporal coherence in cortico-cortical connections: a cross-correlation study in areas 17 and 18 in the cat. *Vis. Neurosci.* *9*, 21–38.
- Neuenschwander, S., and Singer, W. (1996). Long-range synchronization of oscillatory light responses in the cat retina and lateral geniculate nucleus. *Nature* *379*, 728–733.
- Neuenschwander, S., Castelo-Branco, M., and Singer, W. (1999). Synchronous oscillations in the cat retina. *Vision Res.* *39*, 2485–2497.
- Neven, H., and Aertsen, A. (1992). Rate coherence and event coherence in the visual cortex: a neuronal model of object recognition. *Biol. Cybern.* *67*, 309–322.
- Newsome, W.T., Britten, K.H., and Movshon, J.A. (1989). Neuronal correlates of a perceptual decision. *Nature* *341*, 52–54.
- Nicolelis, M.A.L., and Chapin, J.K. (1994). Spatiotemporal structure of somatosensory responses of many-neuron ensembles in the rat ventral posterior medial nucleus of the thalamus. *J. Neurosci.* *14*, 3511–3532.
- Nicolelis, M.A., Ghazanfar, A.A., Stambaugh, C.R., Oliveira, L.M., Laubach, M., Chapin, J.K., Nelson, R.J., and Kaas, J.H. (1998). Simultaneous encoding of tactile information by three primate cortical areas. *Nat. Neurosci.* *1*, 621–630.
- Nicoll, A., and Blakemore, C. (1993). Single-fiber EPSPs in layer 5 of rat visual cortex in-vitro. *Neuroreport* *4*, 167–170.
- Niebur, E., Kammen, D.M., and Koch, C. (1990). Phase-locking in 1-D and 2-D networks of oscillating neurons. In *Nonlinear Dynamics and Neuronal Networks*, H.G. Schuster, ed. (Weinheim: VCH Publishers).
- Niebur, E., Koch, C., and Rosin, C. (1993). An oscillation-based model for the neuronal basis of attention. *Vision Res.* *33*, 2789–2802.
- Nobre, A.C., Sebestyen, G.N., Gitelman, D.R., Mesulam, M.M., Frackowiak, R.S., and Frith, C.D. (1997). Functional localization of the system for visuospatial attention using positron emission tomography. *Brain* *120*, 515–533.
- Nothdurft, H.C. (1992). Feature analysis and the role of similarity in pre-attentive vision. *Percept. Psychophys.* *52*, 355–375.
- Nothdurft, H.C. (1993). Faces and facial expression do not pop-out. *Perception* *22*, 1287–1298.
- Nowak, L.G., Munk, M.H., Girard, P., and Bullier, J. (1995a). Visual latencies in areas V1 and V2 of the macaque monkey. *Vis. Neurosci.* *12*, 371–384.
- Nowak, L.G., Munk, M.H., Nelson, J.I., James, A.C., and Bullier, J. (1995b). Structural basis of cortical synchronization. I. Three types of interhemispheric coupling. *J. Neurophysiol.* *74*, 2379–2400.
- Nowak, L.G., Munk, M.H., James, A.C., Girard, P., and Bullier, J. (1999). Cross-correlation study of the temporal interactions between areas V1 and V2 of the macaque monkey. *J. Neurophysiol.* *81*, 1057–1074.
- Nowlan, S., and Sejnowski, T. (1995). A selection model for motion processing in area MT of primates. *J. Neurosci.* *15*, 1195–1214.
- Okada, K., Steffens J., Maurer, T., Hong, H., Elagin, E., Neven, H., and von der Malsburg, C. (1998). The Bochum/USC face recognition system and how it fared in the FERET phase III test. In *Face Recognition: From Theory to Applications*, H. Wechsler, P.J. Phillips, V. Bruce, F. Fogelman-Souli, and T.S. Huang, eds. (New York: Springer-Verlag).
- O'Keefe, L.P., and Movshon, J.A. (1998). Processing of first- and second-order motion signals by neurons in area MT of the macaque monkey. *Vis. Neurosci.* *15*, 305–317.
- Oliva, A., and Schyns, P.G. (1997). Coarse blobs or fine edges? Evidence that information diagnosticity changes the perception of complex visual stimuli. *Cogn. Psychol.* *34*, 72–107.
- Olshausen, B.A., Anderson, C.H., and Van Essen, D.C. (1993). A neurobiological model of visual attention and invariant pattern recognition based on dynamic routing of information. *J. Neurosci.* *13*, 4700–4719.
- Olshausen, B., Anderson, C., and Van Essen, D. (1995). A multiscale dynamic routing circuit for forming size- and position-invariant object representations. *J. Comput. Neurosci.* *2*, 45–62.
- Orban, G.A., Kennedy, H., and Bullier, J. (1986). Velocity sensitivity and direction selectivity of neurons in areas V1 and V2 of the monkey: influence of eccentricity. *J. Neurophysiol.* *56*, 462–480.
- Pal, N.R., and Pal, S.K. (1993). A review of image segmentation techniques. *Pattern Recog. Lett.* *26*, 1277–1294.
- Palm, G. (1981). Towards a theory of cell assemblies. *Biol. Cybern.* *39*, 181–194.
- Palm, G. (1990). Cell assemblies as a guideline for brain research. *Concepts Neurosci.* *1*, 133–137.
- Palm, G., Aertsen, A., and Gerstein, G.L. (1988). On the significance of correlations among neuronal spike trains. *Biol. Cybern.* *59*, 1–11.
- Parker, A.J., and Newsome, W.T. (1998). Sense and the single neuron: probing the physiology of perception. *Annu. Rev. Neurosci.* *21*, 227–277.
- Perkel, D.H., Gerstein, G.L., and Moore, G.P. (1967). Neuronal spike trains and stochastic point processes. I. The single spike train. *Biophys. J.* *7*, 391–418.
- Perrett, D., and Oram, M. (1993). Neurophysiology of shape processing. *Imag. Vis. Comput.* *11*, 317–333.
- Perrett, D., and Oram, M. (1998). Visual recognition based on temporal cortex cells: viewer-centred processing of pattern configuration. *Z. Naturforsch.* *53c*, 518–541.
- Perrett, D.I., Smith, P.A.J., Potter, D.D., Mistlin, A.J., Head, A.S., Milner, A.D., and Jeeves, M.A. (1984). Neurones responsive to faces

- in the temporal cortex: studies of functional organization, sensitivity to identity and relation to perception. *Hum. Neurobiol.* 3, 197–208.
- Perrett, D.I., Smith, P.A.J., Potter, D.D., Mistlin, A.J., Head, A.S., Milner, A.D., and Jeeves, M.A. (1985). Visual cells in the temporal cortex sensitive to face view and gaze direction. *Proc. R. Soc. Lond. B Biol. Sci.* 223, 293–317.
- Perrett, D.I., Mistlin, A.J., and Chitty, A.J. (1987). Visual neurones responsive to faces. *Trends Neurosci.* 10, 358–364.
- Perrett, D., Oram, M., Harries, M., Bevan, R., Hietanen, J., Benson, P., and Thomas, S. (1991). Viewer-centred and object-centred coding of heads in the macaque temporal cortex. *Exp. Brain Res.* 86, 159–173.
- Peterhans, E., and von der Heydt, R. (1993). Functional organization of area V2 in the alert macaque. *J. Neurosci.* 5, 509–524.
- Peters, A., and Sethares, C. (1991). Organization of pyramidal neurons in area 17 of monkey visual cortex. *J. Comp. Neurol.* 306, 1–23.
- Peters, A., and Yilmaz, E. (1993). Neuronal organization in area 17 of cat visual cortex. *Cereb. Cortex* 3, 49–68.
- Phillips, W.A., and Singer, W. (1997). In search of common foundations for cortical computation. *Behav. Brain Sci.* 20, 657–722.
- Phillips, W.A., Hancock, P.J.B., Willson, N.J., and Smith, L.S. (1988). On the acquisition of object concepts from sensory data. In *Neural Computers*. R. Eckmiller and C. von der Malsburg, eds. (Heidelberg: Springer).
- Phillips, P.J., Moon, H., Rizvi, S., and Rauss, P. (1998). The FERET valuation. In *Face Recognition: From Theory to Applications*. H. Wechsler, P.J. Phillips, V. Bruce, F. Fogelman-Souli, and T.S. Huang, eds. (New York: Springer-Verlag).
- Platt, M.L., and Glimcher, P.W. (1997). Responses of intraparietal neurons to saccadic targets and visual distractors. *J. Neurophysiol.* 78, 1574–1589.
- Plenz, D., and Kitai, S.T. (1996). Generation of high-frequency oscillations in local circuits of rat somatosensory cortex cultures. *J. Neurophysiol.* 76, 4180–4184.
- Poggio, T., and Edelman, S. (1990). A network that learns to recognize 3D objects. *Nature* 343, 263–266.
- Poggio, G.F., and Fischer, B. (1977). Binocular interaction and depth sensitivity in striate and prestriate cortex of behaving rhesus monkey. *J. Neurophysiol.* 40, 1392–1405.
- Poggio, T., Reichardt, W., and Hausen, W. (1981). A neuronal circuitry for relative movement discrimination by the visual system of the fly. *Naturwissenschaften* 68, 443–466.
- Polat, U., Sagi, D., and Norcia, A. (1997). Abnormal long-range spatial interactions in amblyopia. *Vision Res.* 37, 737–744.
- Polat, U., Mizobe, K., Pettet, M.W., Kasamatsu, T., and Norcia, A.M. (1998). Collinear stimuli regulate visual responses depending on a cell's contrast threshold. *Nature* 391, 580–584.
- Pomerantz, J. (1981). Perceptual organization in information processing. In *Perceptual Organization*, M. Kubovy and J. Pomerantz, eds. (Hillsdale, NJ: Lawrence Erlbaum Associates).
- Potter, M. (1975). Meaning in visual search. *Science* 187, 565–566.
- Potter, M.C., and Levy, E.I. (1969). Recognition memory for a rapid sequence of pictures. *J. Exp. Psychol.* 81, 10–15.
- Pouget, A., and Sejnowski, T.J. (1997). A new view of hemineglect based on the response properties of parietal neurones. *Philos. Trans. R. Soc. Lond. B Biol. Sci.* 352, 1449–1459.
- Prinzmetal, W. (1981). Principles of feature integration in visual perception. *Percept. Psychophys.* 30, 330–340.
- Prinzmetal, W., and Keysar, B. (1989). Functional theory of illusory conjunctions and neon colors. *J. Exp. Psychol. Gen.* 118, 165–190.
- Prinzmetal, W., Presti, D.E., and Posner, M.I. (1986). Does attention affect visual feature integration? *J. Exp. Psychol. Hum. Percept. Perform.* 12, 361–369.
- Prinzmetal, W., Henderson, D., and Ivry, R. (1995). Loosening the constraints on illusory conjunctions: assessing the roles of exposure duration and attention. *J. Exp. Psychol. Hum. Percept. Perform.* 21, 1362–1375.
- Prut, Y., Vaadia, E., Bergman, H., Haalman, I., Slovlin, H., and Abeles, M. (1998). Spatiotemporal structure of cortical activity: properties and behavioral relevance. *J. Neurophysiol.* 7, 2857–2874.
- Pulvermüller, F., Birbaumer, N., Lutzenberger, W., and Mohr, B. (1997). High frequency brain activity: its possible role in attention, perception and language processing. *Prog. Neurobiol.* 52, 427–445.
- Purves, D., and LaMantia, A.-S. (1990). Number of 'blobs' in the primary visual cortex of neonatal and adult monkeys. *Proc. Natl. Acad. Sci. USA* 87, 5764–5767.
- Qian, N., and Andersen, R.A. (1994). Transparent motion perception as detection of unbalanced motion signals. II. Physiology. *J. Neurosci.* 14, 7367–7380.
- Quinlan, P.T., and Humphreys, G.W. (1987). Visual search for targets defined by combinations of color, shape, and size: an examination of the task constraints on feature and conjunction searches. *Percept. Psychophys.* 41, 455–472.
- Rafal, R.D. (1997). Balint syndrome. In *Behavioral neurology and Neuropsychology*, T.E. Feinberg and M.J. Farah, eds. (New York: McGraw-Hill).
- Rager, G., and Singer, W. (1998). The response of cat visual cortex to flicker stimuli of variable frequency. *Eur. J. Neurosci.* 10, 1856–1877.
- Raiguel, S.E., Lagae, L., Gulyas, B., and Orban, G.A. (1989). Response latencies of visual cells in macaque areas V1, V2 and V5. *Brain Res.* 493, 155–159.
- Rainer, G., Asaad, W.F., and Miller, E.K. (1998). Memory fields of neurons in the primate prefrontal cortex. *Proc. Natl. Acad. Sci. USA* 95, 15008–15013.
- Recanzone, G.H., Wurtz, R.H., and Schwarz, U. (1997). Responses of MT and MST neurons to one and two moving objects in the receptive field. *J. Neurophysiol.* 78, 2904–2915.
- Reitboeck, H.J., Eckhorn, R., and Pabst, M. (1987). A model of figure/ground separation based on correlated neural activity in the visual system. In *Synergetics of the Brain*, H. Haken, ed. (New York: Springer).
- Rensink, R.A., and Enns, J.T. (1995). Preemption effects in visual search: evidence for low-level grouping. *Psychol. Rev.* 102, 101–130.
- Reyes, A.D., and Fetz, E.E. (1993). Two modes of interspike interval shortening by brief transient depolarizations in cat neocortical neurons. *J. Neurophysiol.* 69, 1661–1672.
- Reyes, A., Rubel, E., and Spain, W. (1994). Membrane properties underlying the firing of neurons in the avian cochlear nucleus. *J. Neurosci.* 14, 5352–5364.
- Reyes, A., Rubel, E., and Spain, W. (1996). In vitro analysis of optimal stimuli for phase-locking and time-delayed modulation of firing in avian nucleus laminaris neurons. *J. Neurosci.* 16, 993–1007.
- Reynolds, J.H., and Desimone, R. (1999). The role of neural mechanisms of attention in solving the binding problem. *Neuron* 24, this issue, 19–29.
- Reynolds, J., Chelazzi, L., and Desimone, R. (1999). Competitive mechanisms subserve attention in macaque areas V2 and V4. *J. Neurosci.* 19, 1736–1753.
- Rhodes, P., and Gray, C.M. (1994). Simulations of intrinsically bursting neocortical pyramidal neurons. *Neural Comput.* 6, 1086–1110.
- Ribary, U., Joannides, A.A., Singh, K.D., Hasson, R., Bolton, J.P.R., Lado, F., Mogilner, A., and Llinas, R. (1991). Magnetic field tomography of coherent thalamocortical 40 Hz oscillations in humans. *Proc. Natl. Acad. Sci. USA* 88, 11037–11041.
- Riehle, A., Grun, S., Diesmann, M., and Aertsen, A. (1997). Spike synchronization and rate modulation differentially involved in motor cortical function. *Science* 278, 1950–1953.
- Riesenhuber, M., and Poggio, T. (1998a). Just one view: invariances in inferotemporal cell tuning. In *Advances in Neural Information Processing Systems*, Volume 10, M. Jordan, M. Kearns, and S. Solla, eds. (Cambridge, MA: MIT Press).
- Riesenhuber, M., and Poggio, T. (1998b). Modeling Invariances in Inferotemporal Cell Tuning, Technical Report 1629 (Cambridge, MA: MIT Artificial Intelligence Laboratory).
- Riesenhuber, M., and Poggio, T. (1999a). Are cortical models really bound by the "binding problem"? *Neuron* 24, this issue, 87–93.
- Riesenhuber, M., and Poggio, T. (1999b). Hierarchical models of object recognition in cortex. *Nat. Neurosci.*, in press.
- Rizzolatti, G., Fogassi, L., and Gallese, V. (1997). Parietal cortex: from sight to action. *Curr. Opin. Neurobiol.* 7, 562–567.

- Robertson, L., Treisman, A., Freidman-Hill, S., and Grabowecky, M. (1997). The interaction of spatial and object pathways: evidence from Balint's syndrome. *J. Cogn. Neurosci.* 9, 254–276.
- Rock, I., and Brosgole, L. (1964). Grouping based on phenomenal proximity. *J. Exp. Psychol.* 67, 531–538.
- Rockel, A.J., Hiorns, R.W., and Powell, T.P.S. (1980). The basic uniformity in structure of the neocortex. *Brain* 103, 221–244.
- Rockland, K.S. (1997). Elements of cortical architecture: hierarchy revisited. In *Cerebral Cortex: Extrastriate Cortex in Primate*, K. Rockland, J. Kaas, and A. Peters, eds. (New York: Plenum Publishing Corporation).
- Rockland, K.S., and Lund, J.S. (1982). Widespread periodic intrinsic connections in the tree shrew visual cortex. *Science* 215, 1532–1534.
- Rockland, K.S., and Van Hoesen, G.W. (1994). Direct temporal-occipital feedback connections to striate cortex (V1) in the macaque monkey. *Cereb. Cortex* 4, 300–313.
- Rodman, H.R., and Albright, T.D. (1989). Single-unit analysis of pattern-motion selective properties in the middle temporal visual area (MT). *Exp. Brain Res.* 75, 53–64.
- Rodriguez, E., George, N., Lachaux, J.-P., Martinerie, J., Renault, B., and Varela, F.J. (1999). Perception's shadow: long-distance gamma band synchronization of human brain activity. *Nature* 397, 430–433.
- Roe, A.W., and Ts'o, D.Y. (1995). Visual topography in primate V2: multiple representation across functional stripes. *J. Neurosci.* 15, 3689–3715.
- Roelfsema, P.R., and Singer, W. (1998). Detecting connectedness. *Cereb. Cortex* 8, 385–396.
- Roelfsema, P.R., König, P., Engel, A.K., Sireteanu, R., and Singer, W. (1994). Reduced synchronization in the visual cortex of cats with strabismic amblyopia. *Eur. J. Neurosci.* 6, 1645–1655.
- Roelfsema, P.R., Engel, A.K., König, P., and Singer, W. (1996). The role of neuronal synchronization in response selection: A biologically plausible theory of structured representations in the visual cortex. *J. Cogn. Neurosci.* 8, 603–625.
- Roelfsema, P.R., Engel, A.K., König, P., and Singer, W. (1997). Visuo-motor integration is associated with zero time-lag synchronization among cortical areas. *Nature* 385, 157–161.
- Rolls, D.T., and Tovee, M.J. (1994). Processing speed in the cerebral cortex and the neurophysiology of visual masking. *Proc. R. Soc. Lond. B Biol. Sci.* 257, 9–15.
- Rolls, E., and Tovee, M. (1995). The responses of single neurons in the temporal visual cortical areas of the macaque when more than one stimulus is present in the receptive field. *Exp. Brain Res.* 103, 409–420.
- Rosenblatt, F. (1961). *Principles of Neurodynamics: Perceptions and the Theory of Brain Mechanisms*. (Washington, CD: Spartan Books).
- Rosenquist, A.C. (1985). Connections of visual cortical areas in the cat. In *Cerebral Cortex*, A. Peters and E.G. Jones, eds. (New York: Plenum Press).
- Rougeul, A., Bouyer, J.J., Dedet, L., and Debray, O. (1979). Fast somato-parietal rhythms during combined focal attention and immobility in baboon and squirrel monkey. *Electroenceph. Clin. Neurophysiol.* 46, 310–319.
- Saarinen, J. (1996a). Localization and discrimination of "pop-out" target. *Vision Res.* 36, 313–316.
- Saarinen, J. (1996b). Target localization and identification in rapid visual search. *Perception* 25, 305–312.
- Sagi, D., and Julesz, B. (1985). "Where" and "what" in vision. *Science* 228, 1217–1219.
- Saito, H., Yukie, M., Tanaka, K., Hikosaka, K., Fukada, Y., and Iwai, E. (1986). Integration of direction signals of image motion in the superior temporal sulcus of the macaque monkey. *J. Neurosci.* 6, 145–157.
- Sakai, K., and Miyashita, Y. (1991). Neural organization for the long-term memory of paired associates. *Nature* 354, 152–155.
- Sakai, K., and Miyashita, Y. (1994). Neuronal tuning to learned complex forms in vision. *Neuroreport* 5, 829–832.
- Sakata, H., Taira, M., Murata, A., and Mine, S. (1995). Neural mechanisms of visual guidance of hand action in the parietal cortex of the monkey. *Cereb. Cortex* 5, 429–438.
- Salin, P.A., and Bullier, J. (1995). Corticocortical connections in the visual system: structure and function. *Physiol. Rev.* 75, 107–154.
- Sanes, J.N., and Donoghue, J.P. (1993). Oscillations in local field potentials of the primate motor cortex during voluntary movement. *Proc. Natl. Acad. Sci. USA* 90, 4470–4474.
- Sato, T. (1989). Interactions of visual stimuli in the receptive fields of inferior temporal neurons in awake monkeys. *Exp. Brain Res.* 77, 23–30.
- Schein, S.J., and Desimone, R. (1990). Spectral properties of V4 neurons in the macaque. *J. Neurosci.* 10, 3369–3389.
- Schein, S.J., Marrocco, R.T., and de Monasterio, F.M. (1982). Is there a high concentration of color-selective cells in area V4 of monkey visual cortex? *J. Neurophysiol.* 47, 193–213.
- Schiller, J., Schiller, Y., Stuart, G., and Sakmann, B. (1997). Calcium action potentials restricted to distal apical dendrites of rat neocortical pyramidal neurons. *J. Physiol.* 505, 605–616.
- Schmidt, K.E., Goebel, R., Löwel, S., and Singer, W. (1997a). The perceptual grouping criterion of collinearity is reflected by anisotropies of connections in the primary visual cortex. *Eur. J. Neurosci.* 9, 1083–1089.
- Schmidt, K.E., Kim, D.-S., Singer, W., Bonhoeffer, T., and Löwel, S. (1997b). Functional specificity of long-range intrinsic and interhemispheric connections in the visual cortex of strabismic cats. *J. Neurosci.* 17, 5480–5492.
- Schmolesky, M.T., Wang, Y., Hanes, D.P., Thompson, K.G., Leutgeb, S., Schall, J.D., and Leventhal, A.G. (1998). Signal timing across the macaque visual system. *J. Neurophysiol.* 79, 3272–3278.
- Schroeder, C.E., Mehta, A.D., and Givre, S.J. (1998). A spatiotemporal profile of visual system activation revealed by current source density analysis in the awake macaque. *Cereb. Cortex* 8, 575–592.
- Schuster, H.G., and Wagner, P. (1990). A model for neuronal oscillations in the visual cortex. 2. Phase description of the feature dependent synchronization. *Biol. Cybern.* 64, 83–85.
- Schwarz, C., and Bolz, J. (1991). Functional specificity of the long-range horizontal connections in cat visual cortex: a cross-correlation study. *J. Neurosci.* 11, 2995–3007.
- Schwindt, P.C., and Crill, W.E. (1995). Amplification of synaptic current by persistent sodium conductance in apical dendrite of neocortical neurons. *J. Neurophysiol.* 74, 2220–2224.
- Seidemann, E., and Newsome, W.T. (1999). Effect of spatial attention on the responses of area MT neurons. *J. Neurophysiol.* 81, 1783–1794.
- Sejnowski, T.J. (1981). Skeleton filters in the brain. In *Parallel Models of Associative Memory*, G.E. Hinton and J.A. Anderson, eds. (Hillsdale, NJ: Lawrence Erlbaum Associates).
- Sereno, M.I., and Allman, J.M. (1991). Cortical visual areas in mammals. In *The Neural Basis of Visual Function*, A. Leventhal, ed. (New York: MacMillan).
- Sereno, A.B., and Maunsell, J.H.R. (1998). Shape selectivity in primate lateral intraparietal cortex. *Nature* 395, 500–503.
- Sestokas, A.K., and Lehmkuhle, S. (1988). Response variability of X- and Y-cells in the dorsal lateral geniculate nucleus of the cat. *J. Neurophysiol.* 59, 317–325.
- Shadlen, M.N., and Movshon, J.A. (1999). Synchrony unbound: a critical evaluation of the temporal binning hypothesis. *Neuron* 24, this issue, 67–77.
- Shadlen, M.N., and Newsome, W.T. (1994). Noise, neural codes and cortical organization. *Curr. Opin. Neurobiol.* 4, 569–579.
- Shadlen, M., and Newsome, W. (1995). Is there a signal in the noise? *Curr. Opin. Neurobiol.* 5, 248–250.
- Shadlen, M.N., and Newsome, W.T. (1996). Motion perception: seeing and deciding. *Proc. Natl. Acad. Sci. USA* 93, 628–633.
- Shadlen, M.N., and Newsome, W.T. (1998). The variable discharge of cortical neurons: implications for connectivity, computation, and information coding. *J. Neurosci.* 18, 3870–3896.
- Shastri, L., and Ajanagadde, V. (1993). From simple associations to systematic reasoning. *Behav. Brain Sci.* 16, 417–494.
- Sheinberg, D.L., and Logothetis, N.K. (1997). The role of temporal cortical areas in perceptual organization. *Proc. Natl. Acad. Sci. USA* 94, 3408–3413.

- Shimojo, S., Silverman, G.H., and Nakayama, K. (1989). Occlusion and the solution to the aperture problem for motion. *Vision Res.* 29, 619–626.
- Sillito, A.M., Grieve, K.L., Jones, H.L., Cuderio, J., and Davis, J. (1995). Visual cortical mechanisms detecting focal orientation discontinuities. *Nature* 378, 492–496.
- Silverman, M.S., Grosf, D.H., DeValois, R.L., and Elfar, S.D. (1989). Spatial-frequency organization in primate striate cortex. *Proc. Natl. Acad. Sci. USA* 86, 711–715.
- Simons, D.J., and Levin, D.T. (1997). Change blindness. *Trends Cogn. Sci.* 1, 261–268.
- Singer, W. (1993). Synchronization of cortical activity and its putative role in information processing and learning. *Annu. Rev. Physiol.* 55, 349–374.
- Singer, W. (1994). Putative functions of temporal correlations in neocortical processing. In *Large-Scale Neuronal Theories of the Brain*, C. Koch and J.L. Davis, eds. (Cambridge, MA: MIT Press).
- Singer, W. (1995). Development and plasticity of cortical processing architectures. *Science* 270, 758–764.
- Singer, W. (1999a). Response synchronization: a universal coding strategy for the definition of relations. In *The Cognitive Neurosciences*, M.S. Gazzaniga, ed. (Cambridge, MA: MIT Press).
- Singer, W. (1999b). Neuronal synchrony: a versatile code for the definition of relations? *Neuron* 24, this issue, 49–65.
- Singer, W., and Gray, C.M. (1995). Visual feature integration and the temporal correlation hypothesis. *Annu. Rev. Neurosci.* 18, 555–586.
- Singer, W., Engel, A.K., Kreiter, A.K., Munk, M.H.J., Neuenschwander, S., and Roelfsema, P.R. (1997). Neuronal assemblies: necessity, signature and detectability. *Trends Cogn. Sci.* 1, 252–261.
- Skottun, B.C., Bradley, A., Sclar, G., Ohzawa, I., and Freeman, R.D. (1987). The effects of contrast on visual orientation and spatial frequency discrimination: a comparison of single cells and behavior. *J. Neurophysiol.* 57, 773–786.
- Snyder, L.H., Batista, A.P., and Andersen, R.A. (1997). Coding of intention in the posterior parietal cortex. *Nature* 386, 167–170.
- Sompolinsky, H., Golomb, D., and Kleinfeld, D. (1990). Global processing of visual stimuli in a neural network of coupled oscillators. *Proc. Natl. Acad. Sci. USA* 87, 7200–7204.
- Sperry, R.W., Miner, N., and Myers, R.E. (1955). Visual pattern perception following subpial slicing and tantalum wire implantations in the visual cortex. *J. Comp. Physiol. Psychol.* 48, 50–58.
- Spitzer, H., Desimone, R., and Moran, J. (1988). Increased attention enhances both behavioral and neuronal performance. *Science* 240, 338–340.
- Sporns, O., Gally, J.A., Reeke, G.N., and Edelman, G.M. (1989). Reentrant signaling among simulated neuronal groups leads to coherency in their oscillatory activity. *Proc. Natl. Acad. Sci. USA* 86, 7265–7269.
- Sporns, O., Tononi, G., and Edelman, G.M. (1991). Modeling perceptual grouping and figure ground segregation by means of active reentrant connections. *Proc. Natl. Acad. Sci. USA* 88, 129–133.
- Stemmler, M., Usher, M., and Niebur, E. (1995). Lateral interactions in primary visual cortex: a model bridging physiology and psychophysics. *Science* 269, 1877–1880.
- Steriade, M., Timofeev, I., Durmuller, N., and Grenier, F. (1998). Dynamic properties of corticothalamic neurons and local cortical interneurons generating fast rhythmic (30–40 Hz) spike-bursts. *J. Neurophysiol.* 79, 483–490.
- Steriade, M. (1999). Coherent oscillations and short-term plasticity in corticothalamic networks. *Trends Neurosci.* 22, 337–345.
- Stevens, C.F., and Wang, Y. (1995). Facilitation and depression at single central synapses. *Neuron* 14, 795–802.
- Stevens, C.F., and Zador, A.M. (1998). Input synchrony and the irregular firing of cortical neurons. *Nat. Neurosci.* 1, 210–217.
- Stoner, G.R., and Albright, T.D. (1992). Neural correlates of perceptual motion coherence. *Nature* 358, 412–414.
- Stoner, G.R., Albright, T.D., and Ramachandran, V.S. (1990). Transparency and coherence in human motion perception. *Nature* 344, 153–155.
- Stopfer, M., Bhagavan, S., Smith, B.H., and Laurent, G. (1997). Impaired odor discrimination on desynchronization of odor-encoding neural assemblies. *Nature* 390, 70–74.
- Storm, J.F. (1990). Potassium currents in hippocampal pyramidal cells. *Prog. Brain Res.* 83, 161–187.
- Stryker, M.P. (1989). Cortical physiology: is grandmother an oscillation? *Nature* 338, 297–298.
- Stuart, G., and Sakmann, B. (1995). Amplification of EPSPs by axosomatic sodium channels in neocortical pyramidal neurons. *Neuron* 15, 1065–1076.
- Suzuki, S., and Cavanagh, P. (1995). Facial organization blocks access to low-level features: an object inferiority effect. *J. Exp. Psychol. Hum. Percept. Perform.* 21, 901–913.
- Szentagotai, J. (1973). Synaptology of the visual cortex. In *Handbook of Sensory Physiology VII/3B: Visual Centers in the Brain*, R. Jung, ed. (New York: Springer-Verlag).
- Tallon-Baudry, C., and Bertrand, O. (1999). Oscillatory gamma activity in humans and its role in object representation. *Trends Cogn. Sci.* 3, 151–162.
- Tallon-Baudry, C., Bertrand, O., Delpuech, C., and Pernier, J. (1996). Stimulus specificity of phase-locked and non-phase-locked 40 Hz visual responses in human. *J. Neurosci.* 16, 4240–4249.
- Tallon-Baudry, C., Bertrand, O., Delpuech, C., and Pernier, J. (1997). Oscillatory gamma band (30–70 Hz) activity induced by a visual search task in humans. *J. Neurosci.* 17, 722–734.
- Tallon-Baudry, C., Bertrand, O., Peronnet, F., and Pernier, J. (1998). Induced gamma band activity during the delay of a visual short-term memory task in humans. *J. Neurosci.* 18, 4244–4254.
- Tallon-Baudry, C., Kreiter, A.K., and Bertrand, O. (1999). Sustained and transient oscillatory responses in the gamma and beta bands in a visual short-term memory task in humans. *Vis. Neurosci.*, in press.
- Tanaka, K. (1993). Neuronal mechanisms of object recognition. *Science* 262, 685–688.
- Tanaka, K. (1996). Inferotemporal cortex and object vision: stimulus selectivity and columnar organization. *Annu. Rev. Neurosci.* 19, 109–139.
- Tanaka, K., and Saito, H.-A. (1989). Analysis of motion of the visual field by direction, expansion/contraction, and rotation cells clustered in the dorsal part of the medial superior temporal area of the macaque monkey. *J. Neurophysiol.* 62, 626–641.
- Tanaka, K., Hikosaka, K., Saito, H., Yukie, M., Fukada, Y., and Iwai, E. (1986a). Analysis of local and wide-field movements in the superior temporal visual areas of the macaque monkey. *J. Neurosci.* 6, 134–144.
- Tanaka, M., Weber, H., and Creutzfeldt, O.D. (1986b). Visual properties and spatial distribution of neurones in the visual association area on the prelunate gyrus of the awake monkey. *Exp. Brain Res.* 65, 11–37.
- Tanaka, K., Fukada, Y., and Saito, H.A. (1989). Underlying mechanisms of the response specificity of expansion/contraction and rotation cells in the dorsal part of the medial superior temporal area of the macaque monkey. *J. Neurophysiol.* 62, 642–656.
- Tarr, M.J., and Bulthoff, H.H. (1995). Is human object recognition better described by geon-structural-descriptions or by multiple-views? *J. Exp. Psychol. Hum. Percept. Perform.*, in press.
- Theeuwes, J., and Kooi, J.L. (1994). Parallel search for a conjunction of shape and contrast polarity. *Vision Res.* 34, 3013–3016.
- Thomson, A.M., and Deuchars, J. (1997). Synaptic interactions in neocortical local circuits: dual intracellular recordings in vitro. *Cereb. Cortex* 7, 510–522.
- Thomson, A.M., and West, D.C. (1993). Fluctuations in pyramidal-pyramidal excitatory postsynaptic potentials modified by presynaptic firing pattern and postsynaptic membrane potential using paired intracellular recordings in rat neocortex. *Neuroscience* 54, 329–346.
- Thomson, A., Deuchars, J., and West, D. (1993). Single axon excitatory postsynaptic potentials in neocortical interneurons exhibit pronounced paired pulse facilitation. *Neuroscience* 54, 347–360.
- Thorpe, S., Fize, D., and Marlot, C. (1996). Speed of processing in the human visual system. *Nature* 381, 520–522.

- Tiitinen, H., Sinkkonen, J., Reinikainen, K., Alho, K., Lavikainen, J., and Naatanen, R. (1993). Selective attention enhances the auditory 40-Hz transient response in humans. *Nature* 364, 59–60.
- Tipper, S.P., Weaver, B., Jerreat, L.M., and Burak, A.L. (1994). Object-based and environment-based inhibition of return of visual attention. *J. Exp. Psychol. Hum. Percept. Perform.* 20, 478–499.
- Tipper, S.P., and Weaver, B. (1998). The medium of attention: location-based, object-based, or scene-based? In *Visual Attention*, Volume 8, R.D. Wright, ed. (Oxford: Oxford University Press).
- Tong, F., Nakayama, K., Vaughan, J.T., and Kanwisher, N. (1998). Binocular rivalry and visual awareness in human extrastriate cortex. *Neuron* 21, 753–759.
- Tononi, G., and Edelman, G.M. (1998). Consciousness and complexity. *Science* 282, 1846–1851.
- Tononi, G., Sporns, O., and Edelman, G. (1992). Reentry and the problem of integrating multiple cortical areas: simulation of dynamic integration in the visual system. *Cereb. Cortex* 2, 310–335.
- Tononi, G., Srinivasan, R., Russell, D.P., and Edelman, G.M. (1998). Investigating neural correlates of conscious perception by frequency-tagged neuromagnetic responses. *Proc. Natl. Acad. Sci. USA* 95, 3198–3203.
- Tootell, R.B.H., and Hamilton, S.L. (1989). Functional anatomy of the second visual area (V2) in the macaque. *J. Neurosci.* 9, 2620–2644.
- Tootell, R.B.H., and Taylor, J.B. (1995). Anatomical evidence for MT and additional cortical visual areas in humans. *Cereb. Cortex* 1, 39–55.
- Tootell, R.B.H., Dale, A.M., Sereno, M.I., and Malach, R. (1996). New images from human visual cortex. *Trends Neurosci.* 19, 481–489.
- Tovee, M., and Rolls, E. (1992a). Oscillatory activity is not evident in the primate temporal visual cortex with static stimuli. *Neuroreport* 3, 369–372.
- Tovee, M.J., and Rolls, E.T. (1992b). The functional nature of neuronal oscillations. *Trends Neurosci.* 15, 387.
- Toyama, K., Kimura, M., and Tanaka, K. (1981a). Cross-correlation analysis of interneuronal connectivity in cat visual cortex. *J. Neurophysiol.* 46, 191–201.
- Toyama, K., Kimura, M., and Tanaka, K. (1981b). Organization of cat visual cortex as investigated by cross-correlation techniques. *J. Neurophysiol.* 46, 202–214.
- Traub, R.D., Wong, R.K.S., Miles, R., and Michelson, H.B. (1991). A model of a CA3 hippocampal pyramidal neuron incorporating voltage-clamp data on intrinsic conductances. *J. Neurophysiol.* 66, 635–650.
- Traub, R.D., Whittington, M.A., Stanford, I.M., and Jefferys, J.G. (1996). A mechanism for generation of long-range synchronous fast oscillations in the cortex. *Nature* 383, 621–624.
- Treisman, A. (1982). Perceptual grouping and attention in visual search for features and for objects. *J. Exp. Psychol. Hum. Percept. Perform.* 8, 194–214.
- Treisman, A. (1988). Features and objects: the fourteenth Bartlett memorial lecture. *Quart. J. Exp. Psychol.* 40A, 201–237.
- Treisman, A. (1991). Search, similarity and the integration of features between and within dimensions. *J. Exp. Psychol. Hum. Percept. Perform.* 27, 652–676.
- Treisman, A. (1992a). Perceiving and re-perceiving objects. *Am. Psychol.* 47, 862–875.
- Treisman, A. (1992b). Spreading suppression or feature integration? A reply to Duncan and Humphreys. *J. Exp. Psychol. Hum. Percept. Perform.* 18, 589–593.
- Treisman, A. (1993). The perception of features and objects. In *Attention: Selection, Awareness and Control: A Tribute to Donald Broadbent*, A. Baddeley and L. Weiskrantz, eds. (Oxford: Clarendon Press).
- Treisman, A. (1995). Modularity and attention: is the binding problem real? *Vis. Cogn.* 2, 303–311.
- Treisman, A. (1996). The binding problem. *Curr. Opin. Neurobiol.* 6, 171–178.
- Treisman, A. (1998). Feature binding, attention and object perception. *Philos. Trans. R. Soc. Lond. B Biol. Sci.* 353, 1295–1306.
- Treisman, A., and Gelade, G. (1980). A feature-integration theory of attention. *Cogn. Psychol.* 12, 97–136.
- Treisman, A., and Gormican, S. (1988). Feature analysis in early vision: evidence from search asymmetries. *Psychol. Rev.* 95, 15–48.
- Treisman, A., and Kanwisher, N.K. (1998). Perceiving visually-presented objects: recognition, awareness, and modularity. *Curr. Opin. Neurobiol.* 8, 218–226.
- Treisman, A., and Sato, S. (1990). Conjunction search revisited. *J. Exp. Psychol. Hum. Percept. Perform.* 16, 459–478.
- Treisman, A., and Schmidt, H. (1982). Illusory conjunctions in the perception of objects. *Cogn. Psychol.* 14, 107–141.
- Treisman, A., and Souther, J. (1986). Illusory words: the roles of attention and of top-down constraints in conjoining letters to form words. *J. Exp. Psychol. Hum. Percept. Perform.* 12, 3–17.
- Treue, S., and Andersen, R.A. (1996). Neural responses to velocity gradients in macaque cortical area MT. *Vis. Neurosci.* 13, 797–804.
- Treue, S., and Maunsell, J.H.R. (1996). Attentional modulation of visual motion processing in cortical areas MT and MST. *Nature* 382, 539–541.
- Triesch, J., and von der Malsburg, C. (1996). Binding—a proposed experiment and a model. In *Proceedings of the Proceedings of the International Conference on Artificial Neural Networks 1996* (New York: Springer-Verlag).
- Tsal, Y. (1989). Do illusory conjunctions support feature integration theory? A critical review of theory and findings. *J. Exp. Psychol. Hum. Percept. Perform.* 15, 394–400.
- Ts'o, D., and Gilbert, C. (1988). The organization of chromatic and spatial interactions in the primate striate cortex. *J. Neurosci.* 8, 1712–1727.
- Ts'o, D.Y., Gilbert, C.D., and Wiesel, T.N. (1986). Relationships between horizontal interactions and functional architecture in cat striate cortex as revealed by cross-correlation analysis. *J. Neurosci.* 6, 1160–1170.
- Tsotsos, J.K. (1990). Analyzing vision at the complexity level. *Behav. Brain Sci.* 13, 423–445.
- Tsotsos, J.K. (1995). Toward a computational model of visual attention. In *Early Vision and Beyond*, T.V. Pappathomas, ed. (Cambridge, MA: MIT Press).
- Tsotsos, J.K., Culhane, S.N., Wai, W.Y.K., Lai, Y., Davis, N., and Nuflo, F. (1995). Modeling visual attention via selective tuning. *Artif. Intell.* 78, 507–545.
- Ullman, S. (1996). *High-Level Vision* (Cambridge, MA: MIT Press).
- Ungerleider, L., and Haxby, J. (1994). “What” and “Where” in the human brain. *Curr. Opin. Neurobiol.* 4, 157–165.
- Ungerleider, L.G., and Mishkin, M. (1982). Two cortical visual systems. In *Analysis of Visual Behavior*, D.J. Ingle, M.A. Goodale, and R.J.W. Mansfield, eds. (Cambridge, MA: MIT Press).
- Ungerleider, L.G., Gaffan, D., and Pelak, V.S. (1989). Projections from inferior temporal cortex to prefrontal cortex via the uncinate fascicle in rhesus monkeys. *Exp. Brain Res.* 76, 473–484.
- Usher, M., and Donnelly, N. (1998). Visual synchrony affects binding and segmentation in perception. *Nature* 394, 179–182.
- Usrey, W.M., and Reid, R.C. (1999). Synchronous activity in the visual system. *Annu. Rev. Physiol.* 61, 435–456.
- Vaadia, E., and Aertsen, A. (1992). Coding and computation in the cortex: single-neuron activity and cooperative phenomena. In *Information Processing in the Cortex: Experiments and Theory*, A. Aertsen and V. Braitenberg, eds. (New York: Springer-Verlag).
- Vaadia, E., Ahissar, E., Bergman, H., and Lavner, Y. (1991). Correlated activity of neurons: a neural code for higher brain functions? In *Neuronal Cooperativity*, J. Kruger, ed. (Berlin: Springer-Verlag).
- Vaadia, E., Haalman, I., Abeles, M., Bergman, H., Prut, Y., Slovin, H., and Aertsen, A. (1995). Dynamics of neuronal interactions in monkey cortex in relation to behavioural events. *Nature* 373, 515–518.
- Van Essen, D.C., and Anderson, C.H. (1990). Information processing strategies and pathways in the primate retina and visual cortex. In *An Introduction to Neural and Electronic Networks*, S.F. Zornetzer, J.L. Davis, and C. Lau, eds. (New York: Academic Press).
- Van Essen, D.C., and Gallant, J.L. (1994). Neural mechanisms of form and motion processing in the primate visual system. *Neuron* 13, 1–10.

- Van Essen, D.C., and Zeki, S.M. (1978). The topographic organization of rhesus monkey prestriate cortex. *J. Physiol. (Lond.)* 277, 193–226.
- Van Essen, D.C., Anderson, C.H., and Felleman, D.J. (1992). Information processing in the primate visual system: an integrated systems perspective. *Science* 255, 419–423.
- van Vreeswijk, D., Abbott, L.F., and Ermentrout, G.B. (1994). When inhibition not excitation synchronizes neural firing. *J. Comput. Neurosci.* 7, 313–321.
- Varela, F.J. (1995). Resonant cell assemblies: a new approach to cognitive functions and neuronal synchrony. *Biol. Res.* 28, 81–95.
- Vecera, S.P., and Farah, M.J. (1994). Does visual attention select objects or locations? *J. Exp. Psychol. Gen.* 123, 146–160.
- Vogels, R., and Orban, G.A. (1994). Activity of inferior temporal neurons during orientation discrimination with successively presented gratings. *J. Neurophysiol.* 71, 1428–1451.
- Volgushev, M., Chistiakova, M., and Singer, W. (1998). Modification of discharge patterns of neocortical neurons by induced oscillations of the membrane potential. *Neuroscience* 83, 15–25.
- von der Heydt, R., and Dursteler, M.R. (1993). Visual search: monkeys detect conjunctions as fast as features. *Invest. Ophthalmol. Vis. Sci.* 34, 1288.
- von der Malsburg, C. (1981). The correlation theory of brain function. MPI Biophysical Chemistry, Internal Report 81–2. Reprinted in *Models of Neural Networks II* (1994), E. Domany, J.L. van Hemmen, and K. Schulten, eds. (Berlin: Springer).
- von der Malsburg, C. (1985). Nervous structures with dynamical links. *Ber. Bunsenges. Phys. Chem.* 89, 703–710.
- von der Malsburg, C. (1986). Am I thinking assemblies? In *Proceedings of the Trieste Meeting on Brain Theory*, G. Palm and A. Aertsen, eds. (Springer: Berlin).
- von der Malsburg, C. (1988). Pattern recognition by labeled graph matching. *Neural Networks* 1, 141–148.
- von der Malsburg, C. (1995). Binding in models of perception and brain function. *Curr. Opin. Neurobiol.* 5, 520–526.
- von der Malsburg, C. (1999). The what and why of binding: the modeler's perspective. *Neuron* 24, this issue, 95–104.
- von der Malsburg, C., and Bienenstock, E. (1987). A neural network for the retrieval of superimposed connection patterns. *Europhys. Lett.* 3, 1243–1249.
- von der Malsburg, C., and Buhmann, J. (1992). Sensory segmentation with coupled neural oscillators. *Biol. Cybern.* 67, 233–242.
- von der Malsburg, C., and Reiser, K. (1995). Pose invariant object recognition in a neural system. In *Proceedings of the International Conference on Artificial Neural Networks 1995*, F. Fogelman-Souli, J.C. Rault, P. Gallinari, and G. Dreyfus, eds. (New York: Springer-Verlag).
- von der Malsburg, C., and Schneider, W. (1986). A neural cocktail-party processor. *Biol. Cybern.* 54, 29–40.
- von der Malsburg, C., and Singer, W. (1991). Principles of cortical network organization. In *Neurobiology of Neocortex*, P. Rakic and W. Singer, eds. (New York: John Wiley).
- von Helmholtz, H.L.F. (1925). *Treatise on Physiological Optics* (New York: Dover Press).
- Wallis, G., and Rolls, E. (1997). A model of invariant object recognition in the visual system. *Prog. Neurobiol.* 51, 167–294.
- Wandell, B.A. (1999). Computational neuroimaging of human visual cortex. *Annu. Rev. Neurosci.* 22, 145–173.
- Wang, X.-J. (1999). Fast burst firing and short-term synaptic plasticity: a model of neocortical chattering neurons. *Neuroscience* 89, 347–362.
- Wang, X.-J., and Buzsaki, G. (1996). Gamma oscillation by synaptic inhibition in a hippocampal interneuronal network model. *J. Neurosci.* 16, 6402–6413.
- Wang, D.L., Buhmann, J., and von der Malsburg, C. (1990). Pattern segmentation in associative memory. *Neural Comput.* 2, 94–106.
- Wang, Q., Cavanagh, P., and Green, M. (1994). Familiarity and pop-out in visual search. *Percept. Psychophys.* 56, 495–500.
- Wehr, M., and Laurent, G. (1996). Odour encoding by temporal sequences of firing in oscillating neural assemblies. *Nature* 384, 162–166.
- Weisstein, N. (1973). Beyond the yellow Volkswagen detector and the grandmother cell: a general strategy for the exploration of operations in human pattern recognition. In *Contemporary Issues in Cognitive Psychology: The Loyola Symposium*, R.L. Solso, ed. (Washington, DC: Winston/Wiley).
- Wertheimer, M. (1923). Untersuchungen zur Lehre der Gestalt. *Psychol. Forschung* 4, 301–350.
- Wertheimer, M. (1955). Laws of organization in perceptual forms. In *A Source Book of Gestalt Psychology*, W.D. Ellis, ed. (London: Routledge and Kegan Paul).
- Wespapat, V., Tennigkeit, F., and Singer, W. (1999). Oscillations and long-term synaptic plasticity in rat visual cortex. In *From Molecular Neurobiology to Clinical Neuroscience: Proceedings of the 1st Göttingen Conference of the German Neuroscience Society, Volume 1, 27th Göttingen Neurobiology Conference*, N. Elsner and U. Eysel, eds. (Stuttgart: Thieme-Verlag).
- Whittington, M.A., Traub, R.D., and Jefferys, J.G.R. (1995). Synchronized oscillations in interneuron networks driven by metabotropic glutamate receptor activation. *Nature* 373, 612–615.
- Wickelgren, W. (1969). Context-sensitive coding, associative memory, and serial order in (speech) behavior. *Psychol. Rev.* 76, 1–15.
- Wilson, M., and Bower, J.M. (1992). Cortical oscillations and temporal interactions in a computer simulation of piriform cortex. *J. Neurophysiol.* 67, 981–995.
- Wilson, M.A., and McNaughton, B.L. (1993). Dynamics of the hippocampal ensemble code for space. *Science* 261, 1055–1058.
- Wilson, F.A., Scalaidhe, S.P., and Goldman-Rakic, P.S. (1993). Dissociation of object and spatial processing domains in primate prefrontal cortex. *Science* 260, 1955–1958.
- Wiskott, L. (1999). The role of topographical constraints in face recognition. *Pattern Recog. Lett.* 20, 89–96.
- Wiskott, L., and von der Malsburg, C. (1995). Face recognition by dynamic link matching. In *Lateral Interactions in the Cortex: Structure and Function* (electronic book), J. Sirosh, R. Miikkulainen, and Y. Choe, eds., [www.cs.utexas.edu/users/nn/web-pubs/htmlbook96](http://www.cs.utexas.edu/users/nn/web-pubs/htmlbook96).
- Wolfe, J.M. (1992). "Effortless" texture segmentation and "parallel" visual search are not the same thing. *Vision Res.* 32, 757–763.
- Wolfe, J.M. (1994a). Guided Search 2.0: a revised model of visual search. *Psychon. Bull. Rev.* 1, 202–238.
- Wolfe, J.M. (1994b). Visual search in continuous, naturalistic stimuli. *Invest. Ophthalmol. Vis. Sci.* 35, 13–28.
- Wolfe, J.M. (1996). Extending Guided Search: why Guided Search needs a preattentive "item map." In *Converging Operations in the Study of Visual Selective Attention*, A. Kramer, G.H. Cole, and G.D. Logan, eds. (Washington, DC: American Psychological Association).
- Wolfe, J.M. (1998). What do 1,000,000 trials tell us about visual search? *Psychol. Sci.* 9, 33–39.
- Wolfe, J., and Bennett, S. (1996). Preattentive object files: shapeless bundles of basic features. *Vision Res.* 37, 25–44.
- Wolfe, J.M., and Cave, K.R. (1999). The psychophysical evidence for a binding problem in human vision. *Neuron* 24, this issue, 11–17.
- Wolfe, J.M., and Gancarz, G. (1996). Guided Search 3.0: a model of visual search catches up with Jay Enoch 40 years later. In *Basic and Clinical Applications of Vision Science*, V. Lakshminarayanan, ed. (Dordrecht, Netherlands: Kluwer Academic).
- Wolfe, J.M., Cave, K.R., and Franzel, S.L. (1989). Guided Search: an alternative to the Feature Integration model for visual search. *J. Exp. Psychol. Hum. Percept. Perform.* 15, 419–433.
- Wolfe, J.M., Chun, M.M., and Friedman-Hill, S.R. (1995). Making use of text on gradients: visual search and perceptual grouping exploit the same parallel processes in different ways. In *Early Vision and Beyond*, T. Pappathomas, C. Chubb, A. Gorea, and E. Kowler, eds. (Cambridge, MA: MIT Press).
- Würtz, R. (1997). Object recognition robust under translations, deformations, and changes in background. *IEEE Trans. Pattern Anal. Machine Intell.* 19.
- Yantis, S., and Gibson, B.S. (1994). Object continuity in apparent motion and attention. *Can. J. Exp. Psychol.* 48, 182–204.
- Yen, S.-C., and Finkel, L.H. (1998). Extraction of perceptually salient contours by striate cortical networks. *Vision Res.* 38, 719–741.

- Yen, S.-C., Menschik, E.D., and Finkel, L.H. (1999). Perceptual grouping in striate cortical networks mediated by synchronization and desynchronization. *Neurocomputing*, in press.
- Yeshurun, Y., and Carrasco, M. (1998). Attention improves or impairs visual performance by enhancing spatial resolution. *Nature* *396*, 72–75.
- Yeshurun, Y., and Carrasco, M. (1999). Spatial attention improves performance in spatial resolution tasks. *Vision Res.* *39*, 293–306.
- Ylinen, A., Sik, A., Bragin, A., Nadasdy, Z., Jando, G., Szabo, I., and Buzsaki, G. (1995). Sharp wave-associated high-frequency oscillation (200 Hz) in the intact hippocampus: network and intracellular mechanisms. *J. Neurosci.* *15*, 30–46.
- Yoshioka, T., Blasdel, G.G., Levitt, J.B., and Lund, J.S. (1996). Relation between patterns of intrinsic lateral connectivity, ocular dominance, and cytochrome oxidase-reactive regions in macaque monkey striate cortex. *Cereb. Cortex* *6*, 297–310.
- Young, M.P., and Yamane, S. (1992). Sparse population coding of faces in the inferotemporal cortex. *Science* *256*, 1327–1331.
- Young, M.P., Tanaka, K., Yamane, S. (1992). On oscillating neuronal responses in the visual cortex of the monkey. *J. Neurophysiol.* *67*, 1464–1474.
- Yu, A.C., and Margoliash, D. (1996). Temporal hierarchical control of singing in birds. *Science* *273*, 1871–1875.
- Yuste, R., and Tank, D.W. (1996). Dendritic integration in mammalian neurons, a century after Cajal. *Neuron* *16*, 701–716.
- Zeki, S.M. (1978). Functional specialisation in the visual cortex of the rhesus monkey. *Nature* *274*, 423–428.
- Zeki, S. (1983). The distribution of wavelength and orientation selective cells in different areas of monkey visual cortex. *Proc. R. Soc. Lond. B Biol. Sci.* *217*, 449–470.
- Zeki, S., and Shipp, S. (1988). The functional logic of cortical connections. *Nature* *335*, 311–317.
- Zhang, X. (1999). Anticipatory inhibition: an intentional non-spatial mechanism revealed with the distractor previewing technique. PhD thesis, Princeton University, Princeton, NJ.
- Zhang, L.I., Tao, H.W., Holt, C.E., Harris, W.A., and Poo, M. (1998). A critical window for cooperation and competition among developing retinotectal synapses. *Nature* *395*, 37–44.
- Zipser, K., Lamme, V.A.F., and Schiller, P.H. (1996). Contextual Modulation in Primary Visual Cortex. *J. Neurosci.* *16*, 7376–7389.
- Zohary, E., and Hochstein, S. (1989). How serial is serial processing in vision? *Perception* *18*, 191–200.
- Zohary, E., Shadlen, M.N., and Newsome, W.T. (1994). Correlated neuronal discharge rate and its implications for psychophysical performance. *Nature* *370*, 140–143.